

KAMARO

Retail Equipment Castors



An excellent partner for your mobile retail equipments.

A silent companion for your customers, giving them a smooth shopping trip and a peace of mind

Single disc travelator castor has provided shoppers decades of safety trip on and off the autowalks, and still, it is the most popular castor used throughout the retail outlets in the world.

Application:

Mobile retail equipments;
shopping trolleys;
airport baggage trolleys.

Size Available:

50x22, 60x25, 75x25, 100x32,
125x32mm

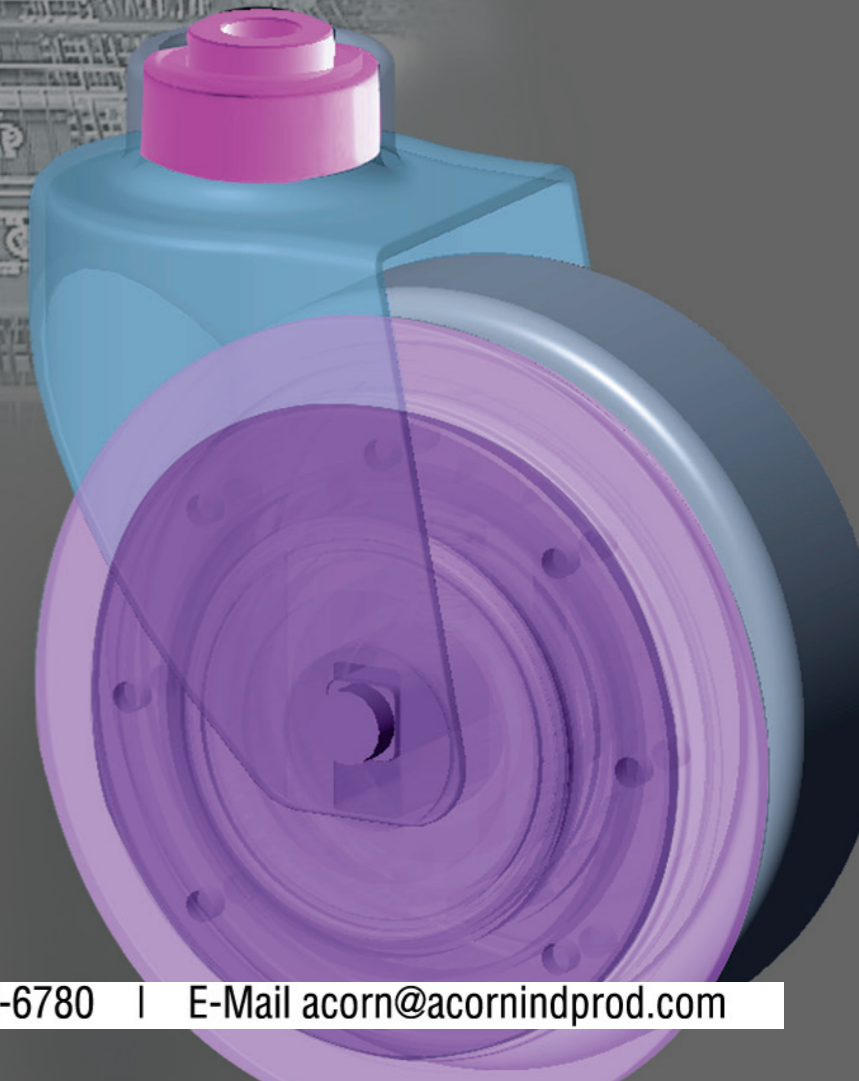















KAMARO

Retail Equipment Castors















Pressed steel, zinc-chromatized double ballrace swivel yoke, designed mainly for shopping trolley and other mobile retail equipments; single disc walkway castor only available in 125mm size

H Bolt Hole Fitting

TPR Wheel Plastic hub, grey color thermoplastic rubber tire

Brake type	 mm	 mm		 mm	 mm	 mm	 kg	Code	
Non-brake Free swivel	75	25		10.3	30.0	103.0	50	Y329H1/W303CX	
	100	32		12.3	35.0	130.5	80	Y429H2/W403	
	125	32		12.3	38.0	154.5	100	Y529H2/W503	
	125	32		12.3	38.0	154.5	100	Y529H2/W503U	
	125	32		12.3	41.5	158.5	100	Y533H2/W503	

TPU Wheel Plastic hub, grey color polyurethane tire

Brake type	 mm	 mm		 mm	 mm	 mm	 kg	Code	
Non-brake Free swivel	50	22		8.3	21.0	66.0	30	Y285H0/W285	
	60	25		10.3	27.0	81.5	40	Y286H1/W286P	
	75	25		12.3	30.0	103.0	50	Y329H2/W305CX	
	100	32		12.3	35.0	130.5	80	Y429H2/W400	
	125	32		12.3	38.0	154.5	100	Y529H2/W500	

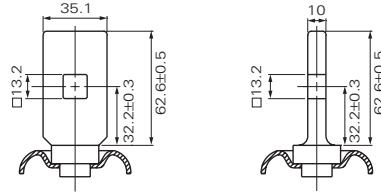

K1 Flange Fitting

H Bolt Hole Fitting

TPU Wheel Plastic hub, grey color polyurethane tire

Brake type	mm	mm		mm	mm	mm	kg	Code
Non-brake Free swivel	100	32		12.3	35.0	130.5	80	Y429H2/W427
	125	32		12.3	38.0	154.5	100	Y529H2/W527
	125	32		12.3	41.5	158.5	100	Y533H2/W527



K Flange Fitting

TPR Wheel Plastic hub, grey color thermoplastic rubber tire

Brake type	mm	mm		mm	mm	mm	kg	Code
Non-brake Free swivel	125	32		38.0	157.5	100	100	Y529K1/W503
	125	32		38.0	157.5	100	100	Y529K1/W503U



TPU Wheel Plastic hub, grey color polyurethane tire

Brake type	mm	mm		mm	mm	mm	kg	Code
Non-brake Free swivel	125	32		38.0	157.5	100	100	Y529K1/W527
	125	32		38.0	157.5	100	100	Y529K1/W500



KAMARO

125mm Travelator Castors

Revision A/2006

Castor designed for mobile equipment used on travelator system

Pressed steel double ballrace swivel yoke, zinc-chromatized, pressed steel hub and threadguard, flanged polyurethane side disc, grey color non-marking rubber tire (80+/-5 Shore A)

Designed for the following palletsize:

Track width: approx. 2.75 mm
Groove width: approx. 5.7 mm
Groove depth: >10.0 mm

Wheel:

Disc wheel: Ø 130 mm
Disc width: 4.5 mm
Engagement travel: 8 mm

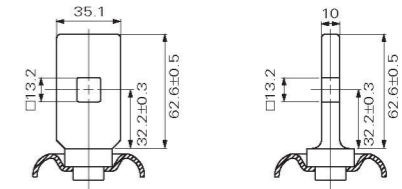

K1 Flange Fitting

R Round Stem

SRB Wheel Pressed steel hub, grey color elastic tire

Free swivel	mm	mm	mm	mm	mm	mm	mm	mm	mm	kg	Code
Left-hand	125	32		22.0	45.0	19.0	M8x1.25	42.5	154.7	100	BKK525R8/W525L
Right-hand	125	32		22.0	45.0	19.0	M8x1.25	42.5	154.7	100	BKK525R8/W525R
Fixed											
Left-hand	125	32		22.0	45.0	19.0	M8x1.25	42.5	154.7	100	BKK525R8F/W525L
Right-hand	125	32		22.0	45.0	19.0	M8x1.25	42.5	154.7	100	BKK525R8F/W525R



K Flange Fitting

SRB Wheel Pressed steel hub, grey color elastic tire

Free swivel	mm	mm	mm	mm	mm	kg	Code
Left-hand	125	32		42.5	155.2	100	BKK525K1/W525L
Right-hand	125	32		42.5	155.2	100	BKK525K1/W525R
Fixed							
Left-hand	125	32		42.5	155.2	100	BKK525K1F/W525L
Right-hand	125	32		42.5	155.2	100	BKK525K1F/W525R



H Bolt Hole Fitting

SRB Wheel Pressed steel hub, grey color elastic tire

Free swivel	mm	mm	mm	mm	mm	mm	kg	Code
Left-hand	125	32		10.3	42.5	152.2	100	BKK525H1/W525L
	125	32		12.3	42.5	152.2	100	BKK525H2/W525L
	125	32		12.8	42.5	152.2	100	BKK525H3/W525L
Right-hand	125	32		10.3	42.5	152.2	100	BKK525H1/W525R
	125	32		12.3	42.5	152.2	100	BKK525H2/W525R
	125	32		12.8	42.5	152.2	100	BKK525H3/W525R

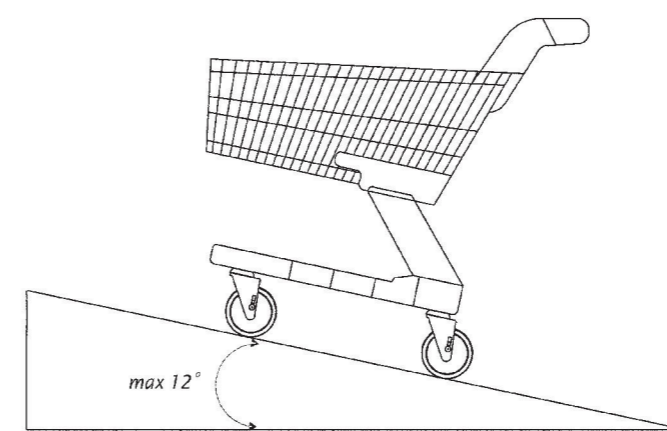

Once trolley landed on the travelator, PU side disc will drop into the pit of the belt, simultaneously locks up the wheel and prevent any movement forward or backward, allowing the user and trolley a safe ride on the travelator. Safety standard requires maximum slope of travelator does not exceed 12°.



On regular flat floor

= 100kgs per castor on level floor



On moving travelator

= 33kgs per castor on travelator