



MIRARO

Standard Castors

A standard castor comes with various choices of mounting parts, wheel selections and braking methods making it a highly versatile component for your mobile institutional equipments.

For more appealing appearance, there is also a choice of bright chrome plating over zinc-chromatized plating finish. Anti-static wheels are much preferred by the electronic industry and, wherever ESD poses a major concern to the manufacturing or assembly process.

Application:

Mobile transport equipments used in electronic industry; general trolleys/carts in airports; and other general institutional applications.

Size Available:

75x25, 100x25, 125x25, 75x32, 100x32, 125x32, 150x32, 200x32mm

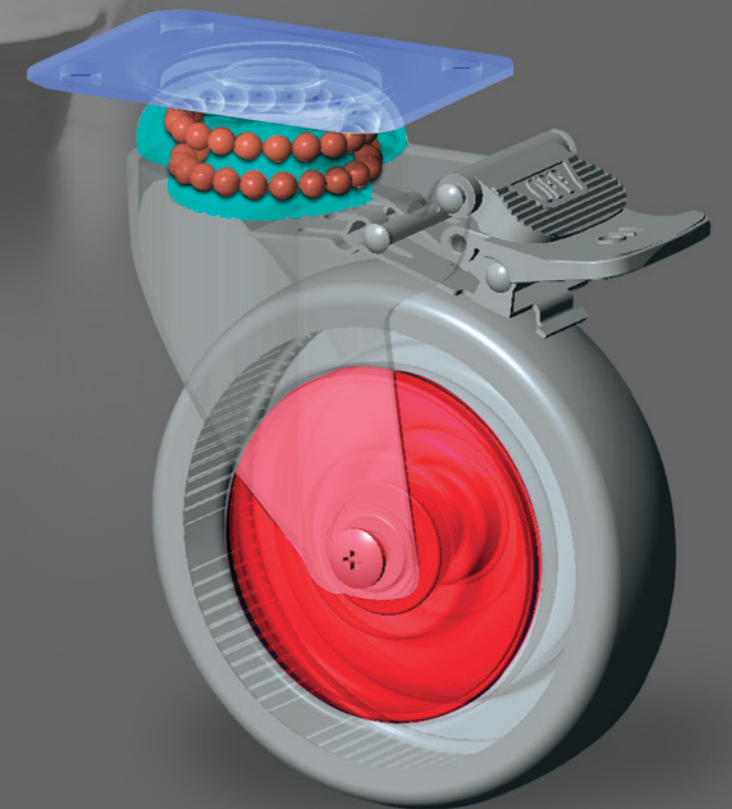
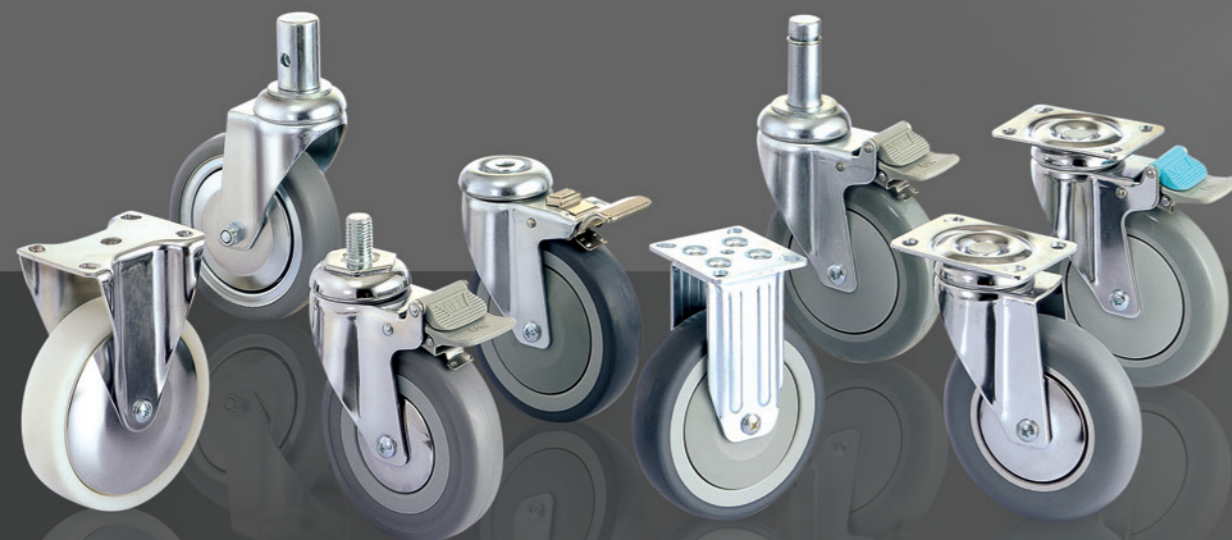

Pressed steel, double ballrace swivel yoke, zinc-chromatized finish

Option: Bright chrome plated finish is also available, add suffix "-CR" to Catis code, e.g. Y580XP1/W503U-CR



TB/A Total locking brake

Total Lock system locks both swivel head and wheel simultaneously for secure parking. Integrated ON/OFF Nylon brake pedals for easy and quiet operation.



DB/A Directional locking brake

Directional Lock permits free wheel rotation while swivel head remains locked, an easy way to keep equipment traveling straight. Integrated ON/OFF Nylon brake pedals for easy and quiet operation. Release pedal in green color.

R Round Stem



PRB Wheel Plastic hub, grey color elastic rubber tire

Brake type	mm	mm		mm	mm	mm	mm	mm	mm	mm	kg	Code
TB/A Total locking brake	100	32		22.0	45.0	19.0	M8x1.25	40.5	135.0	80		Y480XR8/W424
	100	32		28.0	45.0	19.0	M8x1.25	40.5	135.0	80		Y480XR9/W424
	100	32		25.6	45.0	19.0	M8x1.25	40.5	135.0	80		Y480XR16/W424
	125	32		22.0	45.0	19.0	M8x1.25	39.0	161.0	100		Y580XR8/W524
	125	32		28.0	45.0	19.0	M8x1.25	39.0	161.0	100		Y580XR9/W524
	125	32		25.6	45.0	19.0	M8x1.25	39.0	161.0	100		Y580XR16/W524
	150	32		22.0	45.0	19.0	M8x1.25	50.0	189.5	100		Y680XR8/W624
	150	32		28.0	45.0	19.0	M8x1.25	50.0	189.5	100		Y680XR9/W624
	150	32		25.6	45.0	19.0	M8x1.25	50.0	189.5	100		Y680XR16/W624
TB/B Total locking brake	100	32		22.0	45.0	19.0	M8x1.25	40.5	135.0	80		Y480R8/W424
	100	32		28.0	45.0	19.0	M8x1.25	40.5	135.0	80		Y480R9/W424
	100	32		25.6	45.0	19.0	M8x1.25	40.5	135.0	80		Y480R16/W424
	125	32		22.0	45.0	19.0	M8x1.25	39.0	161.0	100		Y580R8/W524
	125	32		28.0	45.0	19.0	M8x1.25	39.0	161.0	100		Y580R9/W524
	125	32		25.6	45.0	19.0	M8x1.25	39.0	161.0	100		Y580R16/W524
	150	32		22.0	45.0	19.0	M8x1.25	46.5	189.5	100		Y680R8/W624
	150	32		28.0	45.0	19.0	M8x1.25	46.5	189.5	100		Y680R9/W624
	150	32		25.6	45.0	19.0	M8x1.25	46.5	189.5	100		Y680R16/W624





TB/ Total locking brake
 Total Lock system simultaneously locks both swivel head and wheel for a secure parking.
 Zinc-alloy brake pedal.

R Round Stem

PRB Wheel Plastic hub, grey color elastic rubber tire

Brake type	mm	mm		mm	mm	mm	mm	mm	mm	mm	kg	Code
DB/ Dir. locking brake	100	32		22.0	45.0	19.0	M8x1.25	40.5	135.0	80		Y480XDR8/W424
	100	32		28.0	45.0	19.0	M8x1.25	40.5	135.0	80		Y480XDR9/W424
	100	32		25.6	45.0	19.0	M8x1.25	40.5	135.0	80		Y480XDR16/W424
	125	32		22.0	45.0	19.0	M8x1.25	39.0	161.0	100		Y580XDR8/W524
	125	32		28.0	45.0	19.0	M8x1.25	39.0	161.0	100		Y580XDR9/W524
	125	32		25.6	45.0	19.0	M8x1.25	39.0	161.0	100		Y580XDR16/W524
	150	32		22.0	45.0	19.0	M8x1.25	50.0	189.5	100		Y680XDR8/W624
	150	32		28.0	45.0	19.0	M8x1.25	50.0	189.5	100		Y680XDR9/W624
	150	32		25.6	45.0	19.0	M8x1.25	50.0	189.5	100		Y680XDR16/W624
Non-brake Free swivel	100	32		22.0	45.0	19.0	M8x1.25	40.5	135.0	80		Y481R8/W424
	100	32		28.0	45.0	19.0	M8x1.25	40.5	135.0	80		Y481R9/W424
	100	32		25.6	45.0	19.0	M8x1.25	40.5	135.0	80		Y481R16/W424
	125	32		22.0	45.0	19.0	M8x1.25	39.0	161.0	100		Y581R8/W524
	125	32		28.0	45.0	19.0	M8x1.25	39.0	161.0	100		Y581R9/W524
	125	32		25.6	45.0	19.0	M8x1.25	39.0	161.0	100		Y581R16/W524
	150	32		22.0	45.0	19.0	M8x1.25	50.0	189.5	100		Y681R8/W624
	150	32		28.0	45.0	19.0	M8x1.25	50.0	189.5	100		Y681R9/W624
	150	32		25.6	45.0	19.0	M8x1.25	50.0	189.5	100		Y681R16/W624



Pressed steel, double ballrace swivel yoke, zinc-chromatized finish

Option: Bright chrome plated finish is also available, add suffix "-CR" to Catis code, e.g. Y580XP1/W503U-CR



TB/A Total locking brake

Total Lock system locks both swivel head and wheel simultaneously for secure parking. Integrated ON/OFF Nylon brake pedals for easy and quiet operation.



DB/A Directional locking brake

Directional Lock permits free wheel rotation while swivel head remains locked, an easy way to keep equipment traveling straight. Integrated ON/OFF Nylon brake pedals for easy and quiet operation. Release pedal in green color.

R Round Stem



SRB Wheel

Pressed steel hub, grey color elastic rubber tire

Brake type	mm	mm	mm	mm	mm	mm	mm	mm	mm	mm	kg	Code
TB/A Total locking brake	100	32		22.0	45.0	19.0	M8x1.25	40.5	135.0	80		Y480XR8/W423
	100	32		28.0	45.0	19.0	M8x1.25	40.5	135.0	80		Y480XR9/W423
	100	32		25.6	45.0	19.0	M8x1.25	40.5	135.0	80		Y480XR16/W423
	125	32		22.0	45.0	19.0	M8x1.25	39.0	161.0	100		Y580XR8/W523
	125	32		28.0	45.0	19.0	M8x1.25	39.0	161.0	100		Y580XR9/W523
	125	32		25.6	45.0	19.0	M8x1.25	39.0	161.0	100		Y580XR16/W523
	150	32		22.0	45.0	19.0	M8x1.25	50.0	189.5	100		Y680XR8/W623
	150	32		28.0	45.0	19.0	M8x1.25	50.0	189.5	100		Y680XR9/W623
	150	32		25.6	45.0	19.0	M8x1.25	50.0	189.5	100		Y680XR16/W623
TB/B Total locking brake	100	32		22.0	45.0	19.0	M8x1.25	40.5	135.0	80		Y480R8/W423
	100	32		28.0	45.0	19.0	M8x1.25	40.5	135.0	80		Y480R9/W423
	100	32		25.6	45.0	19.0	M8x1.25	40.5	135.0	80		Y480R16/W423
	125	32		22.0	45.0	19.0	M8x1.25	39.0	161.0	100		Y580R8/W523
	125	32		28.0	45.0	19.0	M8x1.25	39.0	161.0	100		Y580R9/W523
	125	32		25.6	45.0	19.0	M8x1.25	39.0	161.0	100		Y580R16/W523
	150	32		22.0	45.0	19.0	M8x1.25	46.5	189.5	100		Y680R8/W623
	150	32		28.0	45.0	19.0	M8x1.25	46.5	189.5	100		Y680R9/W623
	150	32		25.6	45.0	19.0	M8x1.25	46.5	189.5	100		Y680R16/W623





TB Total locking brake
 Total Lock system simultaneously locks both swivel head and wheel for a secure parking.
 Zinc-alloy brake pedal.

R Round Stem

SRB Wheel Pressed steel hub, grey color elastic rubber tire

Brake type	mm	mm		mm	mm	mm	mm	mm	mm	mm	kg	Code
DB Dir. locking brake	100	32		22.0	45.0	19.0	M8x1.25	40.5	135.0	80		Y480XDR8/W423
	100	32		28.0	45.0	19.0	M8x1.25	40.5	135.0	80		Y480XDR9/W423
	100	32		25.6	45.0	19.0	M8x1.25	40.5	135.0	80		Y480XDR16/W423
	125	32		22.0	45.0	19.0	M8x1.25	39.0	161.0	100		Y580XDR8/W523
	125	32		28.0	45.0	19.0	M8x1.25	39.0	161.0	100		Y580XDR9/W523
	125	32		25.6	45.0	19.0	M8x1.25	39.0	161.0	100		Y580XDR16/W523
	150	32		22.0	45.0	19.0	M8x1.25	50.0	189.5	100		Y680XDR8/W623
	150	32		28.0	45.0	19.0	M8x1.25	50.0	189.5	100		Y680XDR9/W623
	150	32		25.6	45.0	19.0	M8x1.25	50.0	189.5	100		Y680XDR16/W623
Non-brake Free swivel	100	32		22.0	45.0	19.0	M8x1.25	40.5	135.0	80		Y481R8/W423
	100	32		28.0	45.0	19.0	M8x1.25	40.5	135.0	80		Y481R9/W423
	100	32		25.6	45.0	19.0	M8x1.25	40.5	135.0	80		Y481R16/W423
	125	32		22.0	45.0	19.0	M8x1.25	39.0	161.0	100		Y581R8/W523
	125	32		28.0	45.0	19.0	M8x1.25	39.0	161.0	100		Y581R9/W523
	125	32		25.6	45.0	19.0	M8x1.25	39.0	161.0	100		Y581R16/W523
	150	32		22.0	45.0	19.0	M8x1.25	50.0	189.5	100		Y681R8/W623
	150	32		28.0	45.0	19.0	M8x1.25	50.0	189.5	100		Y681R9/W623
	150	32		25.6	45.0	19.0	M8x1.25	50.0	189.5	100		Y681R16/W623



SRB/BKAS Wheel Conductive wheels are also available

	Code
Pressed steel hub and threadguards, zinc-chromatized finish, black color conductive rubber tire	100 x 32mm W423-BKAS
	125 x 32mm W523-BKAS
Add suffix "-CR" to Catis code for bright chrome finish	150 x 32mm W623-BKAS



Electrical Resistance $\leq 10^4 \Omega$

Pressed steel, double ballrace swivel yoke, zinc-chromatized finish

Option: Bright chrome plated finish is also available, add suffix "-CR" to Catis code, e.g. Y580XP1/W503U-CR



TB/A Total locking brake

Total Lock system locks both swivel head and wheel simultaneously for secure parking. Integrated ON/OFF Nylon brake pedals for easy and quiet operation.



DB/A Directional locking brake

Directional Lock permits free wheel rotation while swivel head remains locked, an easy way to keep equipment traveling straight. Integrated ON/OFF Nylon brake pedals for easy and quiet operation. Release pedal in green color.

R Round Stem



TPR Wheel

Plastic hub, grey color thermoplastic rubber tire

Brake type	mm	mm		mm	mm	mm	mm	mm	mm	mm	kg	Code
TB/A Total locking brake	125	25		22.0	45.0	19.0	M8x1.25	38.5	161.0	70		Y560R8/W512
	125	25		28.0	45.0	19.0	M8x1.25	38.5	161.0	70		Y560R9/W512
	125	25		25.6	45.0	19.0	M8x1.25	38.5	161.0	70		Y560R16/W512
	100	32		22.0	45.0	19.0	M8x1.25	40.5	135.0	80		Y480XR8/W403
	100	32		28.0	45.0	19.0	M8x1.25	40.5	135.0	80		Y480XR9/W403
	100	32		25.6	45.0	19.0	M8x1.25	40.5	135.0	80		Y480XR16/W403
	125	32		22.0	45.0	19.0	M8x1.25	39.0	161.0	100		Y580XR8/W503
	125	32		28.0	45.0	19.0	M8x1.25	39.0	161.0	100		Y580XR9/W503
	125	32		25.6	45.0	19.0	M8x1.25	39.0	161.0	100		Y580XR16/W503
	125	32		22.0	45.0	19.0	M8x1.25	39.0	161.0	100		Y580XR8/W503U
	125	32		28.0	45.0	19.0	M8x1.25	39.0	161.0	100		Y580XR9/W503U
	125	32		25.6	45.0	19.0	M8x1.25	39.0	161.0	100		Y580XR16/W503U
150	32		22.0	45.0	19.0	M8x1.25	50.0	189.5	100		Y680XR8/W603U	
150	32		28.0	45.0	19.0	M8x1.25	50.0	189.5	100		Y680XR9/W603U	
150	32		25.6	45.0	19.0	M8x1.25	50.0	189.5	100		Y680XR16/W603U	

















TB/B Total locking brake
 Total Lock system simultaneously locks both swivel head and wheel for a secure parking.
 Zinc-alloy brake pedal.

R Round Stem

TPR Wheel Plastic hub, grey color thermoplastic rubber tire

Brake type	mm	mm		mm	mm	mm	mm	mm	mm	mm	kg	Code
TB/B Total locking brake	100	32		22.0	45.0	19.0	M8x1.25	40.5	135.0	80		Y480R8/W403
	100	32		28.0	45.0	19.0	M8x1.25	40.5	135.0	80		Y480R9/W403
	100	32		25.6	45.0	19.0	M8x1.25	40.5	135.0	80		Y480R16/W403
	125	32		22.0	45.0	19.0	M8x1.25	39.0	161.0	100		Y580R8/W503
	125	32		28.0	45.0	19.0	M8x1.25	39.0	161.0	100		Y580R9/W503
	125	32		25.6	45.0	19.0	M8x1.25	39.0	161.0	100		Y580R16/W503
	125	32		22.0	45.0	19.0	M8x1.25	39.0	161.0	100		Y580R8/W503U
	125	32		28.0	45.0	19.0	M8x1.25	39.0	161.0	100		Y580R9/W503U
	125	32		25.6	45.0	19.0	M8x1.25	39.0	161.0	100		Y580R16/W503U
	150	32		22.0	45.0	19.0	M8x1.25	46.5	189.5	100		Y680R8/W603U
	150	32		28.0	45.0	19.0	M8x1.25	46.5	189.5	100		Y680R9/W603U
	150	32		25.6	45.0	19.0	M8x1.25	46.5	189.5	100		Y680R16/W603U



Pressed steel, double ballrace swivel yoke, zinc-chromatized finish

Option: Bright chrome plated finish is also available, add suffix "-CR" to Catis code, e.g. Y580XP1/W503U-CR



TB Total locking brake

Total Lock system locks both swivel head and wheel simultaneously for secure parking. Integrated ON/OFF Nylon brake pedals for easy and quiet operation.



DB Directional locking brake

Directional Lock permits free wheel rotation while swivel head remains locked, an easy way to keep equipment traveling straight. Integrated ON/OFF Nylon brake pedals for easy and quiet operation. Release pedal in green color.

R Round Stem



TPR Wheel

Plastic hub, grey color thermoplastic rubber tire

Brake type	mm	mm	mm	mm	mm	mm	mm	mm	mm	mm	kg	Code
DB Dir. locking brake	100	32		22.0	45.0	19.0	M8x1.25	40.5	135.0	80		Y480XDR8/W403
	100	32		28.0	45.0	19.0	M8x1.25	40.5	135.0	80		Y480XDR9/W403
	100	32		25.6	45.0	19.0	M8x1.25	40.5	135.0	80		Y480XDR16/W403
	125	32		22.0	45.0	19.0	M8x1.25	39.0	161.0	100		Y580XDR8/W503
	125	32		28.0	45.0	19.0	M8x1.25	39.0	161.0	100		Y580XDR9/W503
	125	32		25.6	45.0	19.0	M8x1.25	39.0	161.0	100		Y580XDR16/W503
	125	32		22.0	45.0	19.0	M8x1.25	39.0	161.0	100		Y580XDR8/W503U
	125	32		28.0	45.0	19.0	M8x1.25	39.0	161.0	100		Y580XDR9/W503U
	125	32		25.6	45.0	19.0	M8x1.25	39.0	161.0	100		Y580XDR16/W503U
	150	32		22.0	45.0	19.0	M8x1.25	50.0	189.5	100		Y680XDR8/W603U
	150	32		28.0	45.0	19.0	M8x1.25	50.0	189.5	100		Y680XDR9/W603U
	150	32		25.6	45.0	19.0	M8x1.25	50.0	189.5	100		Y680XDR16/W603U





TB Total locking brake
 Total Lock system simultaneously locks both swivel head and wheel for a secure parking.
 Zinc-alloy brake pedal.

R Round Stem

TPR Wheel Plastic hub, grey color thermoplastic rubber tire

Brake type	mm	mm		mm	mm	mm	mm	mm	mm	mm	kg	Code
Non-brake Free swivel	125	25		22.0	45.0	19.0	M8x1.25	38.5	161.0	70		Y561R8/W512
	125	25		28.0	45.0	19.0	M8x1.25	38.5	161.0	70		Y561R9/W512
	125	25		25.6	45.0	19.0	M8x1.25	38.5	161.0	70		Y561R16/W512
	100	32		22.0	45.0	19.0	M8x1.25	40.5	135.0	80		Y481R8/W403
	100	32		28.0	45.0	19.0	M8x1.25	40.5	135.0	80		Y481R9/W403
	100	32		25.6	45.0	19.0	M8x1.25	40.5	135.0	80		Y481R16/W403
	125	32		22.0	45.0	19.0	M8x1.25	39.0	161.0	100		Y581R8/W503
	125	32		28.0	45.0	19.0	M8x1.25	39.0	161.0	100		Y581R9/W503
	125	32		25.6	45.0	19.0	M8x1.25	39.0	161.0	100		Y581R16/W503
	125	32		22.0	45.0	19.0	M8x1.25	39.0	161.0	100		Y581R8/W503U
	125	32		28.0	45.0	19.0	M8x1.25	39.0	161.0	100		Y581R9/W503U
	125	32		25.6	45.0	19.0	M8x1.25	39.0	161.0	100		Y581R16/W503U
	150	32		22.0	45.0	19.0	M8x1.25	50.0	189.5	100		Y681R8/W603U
	150	32		28.0	45.0	19.0	M8x1.25	50.0	189.5	100		Y681R9/W603U
	150	32		25.6	45.0	19.0	M8x1.25	50.0	189.5	100		Y681R16/W603U



TPR/AS Wheel Conductive wheels are also available

		Code
Plastic hub and threadguards, grey color conductive thermoplastic rubber tire	075 x 25mm	W303CX-AS*
	100 x 32mm	W403-AS
	125 x 32mm	W503-AS
	150 x 32mm	W603U-AS



*Wheel with metal threadguards (see P020)

Electrical Resistance $\leq 10^4 \Omega$

Pressed steel, double ballrace swivel yoke, zinc-chromatized finish

Option: Bright chrome plated finish is also available, add suffix "-CR" to Catis code, e.g. Y580XP1/W503U-CR



TB/A Total locking brake

Total Lock system locks both swivel head and wheel simultaneously for secure parking. Integrated ON/OFF Nylon brake pedals for easy and quiet operation.



DB/A Directional locking brake

Directional Lock permits free wheel rotation while swivel head remains locked, an easy way to keep equipment traveling straight. Integrated ON/OFF Nylon brake pedals for easy and quiet operation. Release pedal in green color.

R Round Stem



TPU Wheel Plastic hub, grey color polyurethane tire

Brake type	mm	mm		mm	mm	mm	mm	mm	mm	mm	kg	Code
TB/A Total locking brake	100	32		22.0	45.0	19.0	M8x1.25	40.5	135.0	80		Y480XR8/W400E
	100	32		28.0	45.0	19.0	M8x1.25	40.5	135.0	80		Y480XR9/W400E
	100	32		25.6	45.0	19.0	M8x1.25	40.5	135.0	80		Y480XR16/W400E
	125	32		22.0	45.0	19.0	M8x1.25	39.0	161.0	100		Y580XR8/W500E
	125	32		28.0	45.0	19.0	M8x1.25	39.0	161.0	100		Y580XR9/W500E
	125	32		25.6	45.0	19.0	M8x1.25	39.0	161.0	100		Y580XR16/W500E
	150	32		22.0	45.0	19.0	M8x1.25	50.0	189.5	100		Y680XR8/W600E
	150	32		28.0	45.0	19.0	M8x1.25	50.0	189.5	100		Y680XR9/W600E
	150	32		25.6	45.0	19.0	M8x1.25	50.0	189.5	100		Y680XR16/W600E
TB/B Total locking brake	100	32		22.0	45.0	19.0	M8x1.25	40.5	135.0	80		Y480R8/W400E
	100	32		28.0	45.0	19.0	M8x1.25	40.5	135.0	80		Y480R9/W400E
	100	32		25.6	45.0	19.0	M8x1.25	40.5	135.0	80		Y480R16/W400E
	125	32		22.0	45.0	19.0	M8x1.25	39.0	161.0	100		Y580R8/W500E
	125	32		28.0	45.0	19.0	M8x1.25	39.0	161.0	100		Y580R9/W500E
	125	32		25.6	45.0	19.0	M8x1.25	39.0	161.0	100		Y580R16/W500E
	150	32		22.0	45.0	19.0	M8x1.25	46.5	189.5	100		Y680R8/W600E
	150	32		28.0	45.0	19.0	M8x1.25	46.5	189.5	100		Y680R9/W600E
	150	32		25.6	45.0	19.0	M8x1.25	46.5	189.5	100		Y680R16/W600E





TB Total locking brake
 Total Lock system simultaneously locks both swivel head and wheel for a secure parking.
 Zinc-alloy brake pedal.

R Round Stem

TPU Wheel Plastic hub, grey color polyurethane tire

Brake type	mm	mm		mm	mm	mm	mm	mm	mm	mm	kg	Code
DB Dir. locking brake	100	32		22.0	45.0	19.0	M8x1.25	40.5	135.0	80		Y480XDR8/W400E
	100	32		28.0	45.0	19.0	M8x1.25	40.5	135.0	80		Y480XDR9/W400E
	100	32		25.6	45.0	19.0	M8x1.25	40.5	135.0	80		Y480XDR16/W400E
	125	32		22.0	45.0	19.0	M8x1.25	39.0	161.0	100		Y580XDR8/W500E
	125	32		28.0	45.0	19.0	M8x1.25	39.0	161.0	100		Y580XDR9/W500E
	125	32		25.6	45.0	19.0	M8x1.25	39.0	161.0	100		Y580XDR16/W500E
	150	32		22.0	45.0	19.0	M8x1.25	50.0	189.5	100		Y680XDR8/W600E
	150	32		28.0	45.0	19.0	M8x1.25	50.0	189.5	100		Y680XDR9/W600E
	150	32		25.6	45.0	19.0	M8x1.25	50.0	189.5	100		Y680XDR16/W600E
Non-brake Free swivel	100	32		22.0	45.0	19.0	M8x1.25	40.5	135.0	80		Y481R8/W400E
	100	32		28.0	45.0	19.0	M8x1.25	40.5	135.0	80		Y481R9/W400E
	100	32		25.6	45.0	19.0	M8x1.25	40.5	135.0	80		Y481R16/W400E
	125	32		22.0	45.0	19.0	M8x1.25	39.0	161.0	100		Y581R8/W500E
	125	32		28.0	45.0	19.0	M8x1.25	39.0	161.0	100		Y581R9/W500E
	125	32		25.6	45.0	19.0	M8x1.25	39.0	161.0	100		Y581R16/W500E
	150	32		22.0	45.0	19.0	M8x1.25	50.0	189.5	100		Y681R8/W600E
	150	32		28.0	45.0	19.0	M8x1.25	50.0	189.5	100		Y681R9/W600E
	150	32		25.6	45.0	19.0	M8x1.25	50.0	189.5	100		Y681R16/W600E



Pressed steel, double ballrace swivel yoke, zinc-chromatized finish

Option: Bright chrome plated finish is also available, add suffix "-CR" to Catis code, e.g. Y580XP1/W503U-CR



TB/A Total locking brake

Total Lock system locks both swivel head and wheel simultaneously for secure parking. Integrated ON/OFF Nylon brake pedals for easy and quiet operation.



DB/A Directional locking brake

Directional Lock permits free wheel rotation while swivel head remains locked, an easy way to keep equipment traveling straight. Integrated ON/OFF Nylon brake pedals for easy and quiet operation. Release pedal in green color.

R Round Stem



PM Wheel Solid nylon wheel

Brake type	mm	mm	mm	mm	mm	mm	mm	mm	mm	kg	Code
TB/A Total locking brake	100	32		22.0	45.0	19.0	M8x1.25	40.5	135.0	80	Y480XR8/W409RX
	100	32		28.0	45.0	19.0	M8x1.25	40.5	135.0	80	Y480XR9/W409RX
	100	32		25.6	45.0	19.0	M8x1.25	40.5	135.0	80	Y480XR16/W409RX
	125	32		22.0	45.0	19.0	M8x1.25	39.0	161.0	100	Y580XR8/W509RX
	125	32		28.0	45.0	19.0	M8x1.25	39.0	161.0	100	Y580XR9/W509RX
	125	32		25.6	45.0	19.0	M8x1.25	39.0	161.0	100	Y580XR16/W509RX
TB/B Total locking brake	100	32		22.0	45.0	19.0	M8x1.25	40.5	135.0	80	Y480R8/W409RX
	100	32		28.0	45.0	19.0	M8x1.25	40.5	135.0	80	Y480R9/W409RX
	100	32		25.6	45.0	19.0	M8x1.25	40.5	135.0	80	Y480R16/W409RX
	125	32		22.0	45.0	19.0	M8x1.25	39.0	161.0	100	Y580R8/W509RX
	125	32		28.0	45.0	19.0	M8x1.25	39.0	161.0	100	Y580R9/W509RX
	125	32		25.6	45.0	19.0	M8x1.25	39.0	161.0	100	Y580R16/W509RX





TB Total locking brake
 Total Lock system simultaneously locks both swivel head and wheel for a secure parking.
 Zinc-alloy brake pedal.

R Round Stem



PM Wheel Solid nylon wheel

Brake type	mm	mm		mm	mm	mm	mm	mm	mm	mm	kg	Code
DB Dir. locking brake	100	32		22.0	45.0	19.0	M8x1.25	40.5	135.0	80		Y480XDR8/W409RX
	100	32		28.0	45.0	19.0	M8x1.25	40.5	135.0	80		Y480XDR9/W409RX
	100	32		25.6	45.0	19.0	M8x1.25	40.5	135.0	80		Y480XDR16/W409RX
	125	32		22.0	45.0	19.0	M8x1.25	39.0	161.0	100		Y580XDR8/W509RX
	125	32		28.0	45.0	19.0	M8x1.25	39.0	161.0	100		Y580XDR9/W509RX
	125	32		25.6	45.0	19.0	M8x1.25	39.0	161.0	100		Y580XDR16/W509RX
Non-brake Free swivel	100	32		22.0	45.0	19.0	M8x1.25	40.5	135.0	80		Y481R8/W409RX
	100	32		28.0	45.0	19.0	M8x1.25	40.5	135.0	80		Y481R9/W409RX
	100	32		25.6	45.0	19.0	M8x1.25	40.5	135.0	80		Y481R16/W409RX
	125	32		22.0	45.0	19.0	M8x1.25	39.0	161.0	100		Y581R8/W509RX
	125	32		28.0	45.0	19.0	M8x1.25	39.0	161.0	100		Y581R9/W509RX
	125	32		25.6	45.0	19.0	M8x1.25	39.0	161.0	100		Y581R16/W509RX



Pressed steel, double ballrace swivel yoke, zinc-chromatized finish

Option: Bright chrome plated finish is also available, add suffix "-CR" to Catis code, e.g. Y580XP1/W503U-CR



TB/A Total locking brake

Total Lock system locks both swivel head and wheel simultaneously for secure parking. Integrated ON/OFF Nylon brake pedals for easy and quiet operation.



DB/A Directional locking brake























Directional Lock permits free wheel rotation while swivel head remains locked, an easy way to keep equipment traveling straight. Integrated ON/OFF Nylon brake pedals for easy and quiet operation. Release pedal in green color.

R Round Stem



PP Wheel

Solid polypropylene wheel

Brake type	 mm	 mm		 mm	 mm	 mm	 mm	 mm	 mm	 kg	Code
TB/A Total locking brake	100	32		22.0	45.0	19.0	M8x1.25	40.5	135.0	80	Y480XR8/W410RX
	100	32		28.0	45.0	19.0	M8x1.25	40.5	135.0	80	Y480XR9/W410RX
	100	32		25.6	45.0	19.0	M8x1.25	40.5	135.0	80	Y480XR16/W410RX
	125	32		22.0	45.0	19.0	M8x1.25	39.0	161.0	100	Y580XR8/W510RX
	125	32		28.0	45.0	19.0	M8x1.25	39.0	161.0	100	Y580XR9/W510RX
	125	32		25.6	45.0	19.0	M8x1.25	39.0	161.0	100	Y580XR16/W510RX
TB/B Total locking brake	100	32		22.0	45.0	19.0	M8x1.25	40.5	135.0	80	Y480R8/W410RX
	100	32		28.0	45.0	19.0	M8x1.25	40.5	135.0	80	Y480R9/W410RX
	100	32		25.6	45.0	19.0	M8x1.25	40.5	135.0	80	Y480R16/W410RX
	125	32		22.0	45.0	19.0	M8x1.25	39.0	161.0	100	Y580R8/W510RX
	125	32		28.0	45.0	19.0	M8x1.25	39.0	161.0	100	Y580R9/W510RX
	125	32		25.6	45.0	19.0	M8x1.25	39.0	161.0	100	Y580R16/W510RX





TB Total locking brake
 Total Lock system simultaneously locks both swivel head and wheel for a secure parking.
 Zinc-alloy brake pedal.

R Round Stem



PP Wheel Solid polypropylene wheel

Brake type	mm	mm		mm	mm	mm	mm	mm	mm	mm	kg	Code
DB Dir. locking brake	100	32		22.0	45.0	19.0	M8x1.25	40.5	135.0	80		Y480XDR8/W410RX
	100	32		28.0	45.0	19.0	M8x1.25	40.5	135.0	80		Y480XDR9/W410RX
	100	32		25.6	45.0	19.0	M8x1.25	40.5	135.0	80		Y480XDR16/W410RX
	125	32		22.0	45.0	19.0	M8x1.25	39.0	161.0	100		Y580XDR8/W510RX
	125	32		28.0	45.0	19.0	M8x1.25	39.0	161.0	100		Y580XDR9/W510RX
	125	32		25.6	45.0	19.0	M8x1.25	39.0	161.0	100		Y580XDR16/W510RX
Non-brake Free swivel	100	32		22.0	45.0	19.0	M8x1.25	40.5	135.0	80		Y481R8/W410RX
	100	32		28.0	45.0	19.0	M8x1.25	40.5	135.0	80		Y481R9/W410RX
	100	32		25.6	45.0	19.0	M8x1.25	40.5	135.0	80		Y481R16/W410RX
	125	32		22.0	45.0	19.0	M8x1.25	39.0	161.0	100		Y581R8/W510RX
	125	32		28.0	45.0	19.0	M8x1.25	39.0	161.0	100		Y581R9/W510RX
	125	32		25.6	45.0	19.0	M8x1.25	39.0	161.0	100		Y581R16/W510RX





DURARO

Stainless Steel Castors

Application:
Kitchen trolleys; food carts; food processing plants;
restaurants and commercial kitchens;
laboratory equipments.

Size Available:
75x32, 100x32, 125x32, 150x32, 200x32mm

If your mobile equipment is subjected to frequent contact or exposure to moisture, our Duraro would be your absolute choice of castor.

For the same reason, it is a must for most kitchen and food carts which are constantly moved in and out of refrigerating room and steamy kitchen, then hose cleaned to rid of food debris and oil stain, nothing other than stainless steel can stay shiny under such adverse conditions.

On the other extreme, medical or laboratory equipments that has to be sanitized with disinfectants would find Duraro suitable at all time.

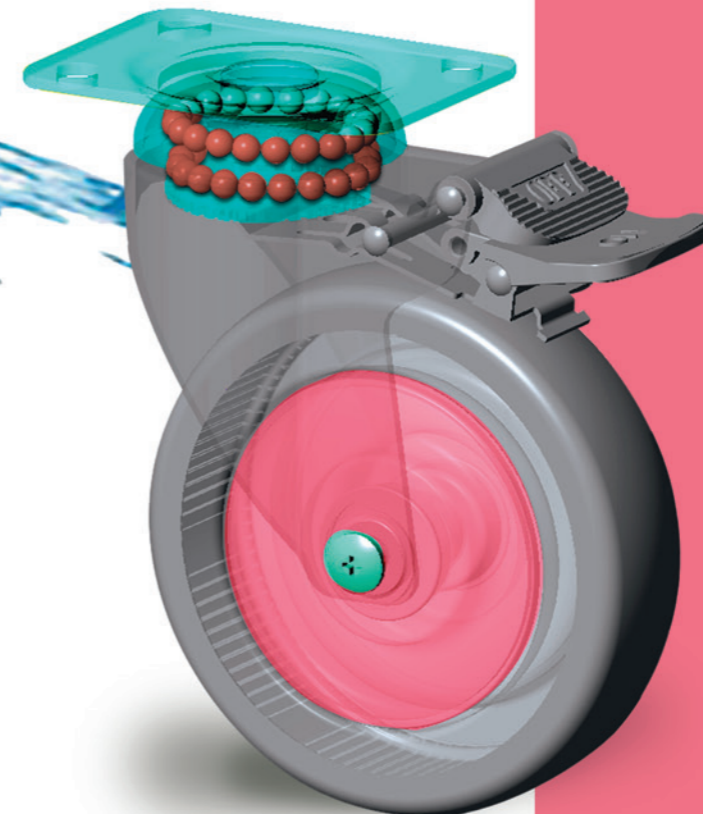

Pressed stainless steel double ballrace swivel yoke, electrolytic polishing finish



TB/A Total locking brake
Total Lock system locks both swivel head and wheel simultaneously for secure parking. Integrated ON/OFF Nylon brake pedals for easy and quiet operation.



DB/A Directional locking brake
Directional Lock permits free wheel rotation while swivel head remains locked, an easy way to keep equipment traveling straight. Integrated ON/OFF Nylon brake pedals for easy and quiet operation. Release pedal in green color.

P Top Plate Fitting

PRB-SS Wheel Plastic hub, grey color elastic rubber tire

Brake type	mm	mm	mm	mm	mm	mm	mm	mm	kg	Code
TB/A Total locking brake	75	32		95 x 70	75 x 52 / 72 x 45	9.0	33.0	107.0	50	Y380XP1SS/W324S
	75	32		77 x 67	61.5 x 52 / 56 x 45	8.5	33.0	107.0	50	Y380XP2SS/W324S
	100	32		95 x 70	75 x 52 / 72 x 45	9.0	40.5	135.0	80	Y480XP1SS/W424DS
	100	32		77 x 67	61.5 x 52 / 56 x 45	8.5	40.5	135.0	80	Y480XP2SS/W424DS
	125	32		95 x 70	75 x 52 / 72 x 45	9.0	39.0	161.0	100	Y580XP1SS/W524DS
	125	32		77 x 67	61.5 x 52 / 56 x 45	8.5	39.0	161.0	100	Y580XP2SS/W524DS
	150	32		95 x 70	75 x 52 / 72 x 45	9.0	50.0	189.5	100	Y680XP1SS/W624DS
	150	32		77 x 67	61.5 x 52 / 56 x 45	8.5	50.0	189.5	100	Y680XP2SS/W624DS
TB/B Total locking brake	75	32		95 x 70	75 x 52 / 72 x 45	9.0	41.0	107.0	50	Y380P1SS/W324S
	75	32		77 x 67	61.5 x 52 / 56 x 45	8.5	41.0	107.0	50	Y380P2SS/W324S
	100	32		95 x 70	75 x 52 / 72 x 45	9.0	40.5	135.0	80	Y480P1SS/W424DS
	100	32		77 x 67	61.5 x 52 / 56 x 45	8.5	40.5	135.0	80	Y480P2SS/W424DS
	125	32		95 x 70	75 x 52 / 72 x 45	9.0	39.0	161.0	100	Y580P1SS/W524DS
	125	32		77 x 67	61.5 x 52 / 56 x 45	8.5	39.0	161.0	100	Y580P2SS/W524DS
	150	32		95 x 70	75 x 52 / 72 x 45	9.0	46.5	189.5	100	Y680P1SS/W624DS
	150	32		77 x 67	61.5 x 52 / 56 x 45	8.5	46.5	189.5	100	Y680P2SS/W624DS

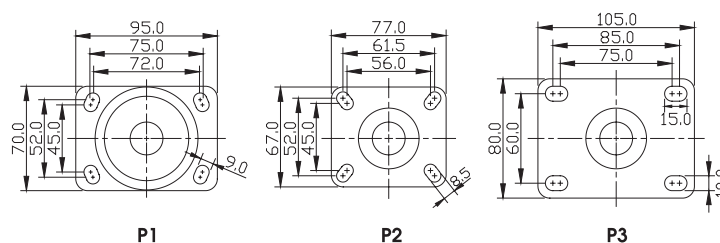























TB Total locking brake
 Total Lock system simultaneously locks both swivel head and wheel for a secure parking.
 Zinc-alloy brake pedal.

P Top Plate Fitting

PRB-SS Wheel Plastic hub, grey color elastic rubber tire

Brake type	mm	mm		mm	mm	mm	mm	mm	kg	Code
DB Dir. locking brake	75	32		95 x 70	75 x 52 / 72 x 45	9.0	33.0	107.0	50	Y380XDP1SS/W324S
	75	32		77 x 67	61.5 x 52 / 56 x 45	8.5	33.0	107.0	50	Y380XDP2SS/W324S
	100	32		95 x 70	75 x 52 / 72 x 45	9.0	40.5	135.0	80	Y480XDP1SS/W424DS
	100	32		77 x 67	61.5 x 52 / 56 x 45	8.5	40.5	135.0	80	Y480XDP2SS/W424DS
	125	32		95 x 70	75 x 52 / 72 x 45	9.0	39.0	161.0	100	Y580XDP1SS/W524DS
	125	32		77 x 67	61.5 x 52 / 56 x 45	8.5	39.0	161.0	100	Y580XDP2SS/W524DS
	150	32		95 x 70	75 x 52 / 72 x 45	9.0	50.0	189.5	100	Y680XDP1SS/W624DS
	150	32		77 x 67	61.5 x 52 / 56 x 45	8.5	50.0	189.5	100	Y680XDP2SS/W624DS
Non-brake Free swivel	75	32		95 x 70	75 x 52 / 72 x 45	9.0	33.0	107.0	50	Y381P1SS/W324S
	75	32		77 x 67	61.5 x 52 / 56 x 45	8.5	33.0	107.0	50	Y381P2SS/W324S
	75	32		105 x 80	85 x 60 / 75 x 60	10.0	33.0	107.0	50	Y381P3SS/W324S
	100	32		95 x 70	75 x 52 / 72 x 45	9.0	40.5	135.0	80	Y481P1SS/W424DS
	100	32		77 x 67	61.5 x 52 / 56 x 45	8.5	40.5	135.0	80	Y481P2SS/W424DS
	100	32		105 x 80	85 x 60 / 75 x 60	10.0	40.5	135.0	80	Y481P3SS/W424DS
	125	32		95 x 70	75 x 52 / 72 x 45	9.0	39.0	161.0	100	Y581P1SS/W524DS
	125	32		77 x 67	61.5 x 52 / 56 x 45	8.5	39.0	161.0	100	Y581P2SS/W524DS
	125	32		105 x 80	85 x 60 / 75 x 60	10.0	39.0	161.0	100	Y581P3SS/W524DS
	150	32		95 x 70	75 x 52 / 72 x 45	9.0	50.0	189.5	100	Y681P1SS/W624DS
	150	32		77 x 67	61.5 x 52 / 56 x 45	8.5	50.0	189.5	100	Y681P2SS/W624DS
	150	32		105 x 80	85 x 60 / 75 x 60	10.0	50.0	189.5	100	Y681P3SS/W624DS



 Stainless steel

Pressed stainless steel double ballrace swivel yoke, electrolytic polishing finish





















TB Total locking brake
Total Lock system locks both swivel head and wheel simultaneously for secure parking. Integrated ON/OFF Nylon brake pedals for easy and quiet operation.



DB Directional locking brake
Directional Lock permits free wheel rotation while swivel head remains locked, an easy way to keep equipment traveling straight. Integrated ON/OFF Nylon brake pedals for easy and quiet operation. Release pedal in green color.

P Top Plate Fitting

PRB-SS Wheel Plastic hub, grey color elastic rubber tire

Brake type	 mm	 mm		 mm	 mm	 mm	 mm	 kg	Code	
Non-brake Fixed	75	32		95 x 77	75 x 52 / 72 x 45	9.0	107.0	50	Y382P1SS/W324S	
	100	32		95 x 77	75 x 52 / 72 x 45	9.0	135.0	80	Y482P1SS/W424DS	
	125	32		95 x 77	75 x 52 / 72 x 45	9.0	161.0	100	Y582P1SS/W524DS	
	150	32		95 x 77	75 x 52 / 72 x 45	9.0	189.5	100	Y682P1SS/W624DS	
	75	32		67 x 77	52 x 61.5 / 45 x 56	8.5	107.0	50	Y385P2SS/W324S	
	100	32		67 x 77	52 x 61.5 / 45 x 56	8.5	135.0	80	Y485P2SS/W424DS	
	125	32		67 x 77	52 x 61.5 / 45 x 56	8.5	161.0	100	Y585P2SS/W524DS	

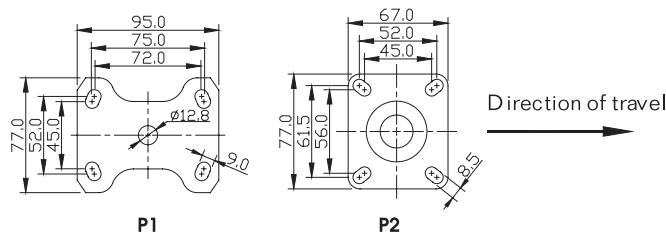



TB/β Total locking brake
 Total Lock system simultaneously locks both swivel head and wheel for a secure parking.
 Zinc-alloy brake pedal.

P Top Plate Fitting

TPR-SS Wheel Plastic hub, grey color thermoplastic rubber tire

Brake type	mm	mm	mm	mm	mm	mm	mm	mm	kg	Code
TB/β Total locking brake	100	32		95 x 70	75 x 52 / 72 x 45	9.0	40.5	135.0	80	Y480XP1SS/W403DS
	100	32		77 x 67	61.5 x 52 / 56 x 45	8.5	40.5	135.0	80	Y480XP2SS/W403DS
	125	32		95 x 70	75 x 52 / 72 x 45	9.0	39.0	161.0	100	Y580XP1SS/W503DS
	125	32		77 x 67	61.5 x 52 / 56 x 45	8.5	39.0	161.0	100	Y580XP2SS/W503DS
	200	32		95 x 70	75 x 52 / 72 x 45	9.0	57.5	235.0	120	Y880XP1SS/W803UXS
TB/β Total locking brake	100	32		95 x 70	75 x 52 / 72 x 45	9.0	40.5	135.0	80	Y480P1SS/W403DS
	100	32		77 x 67	61.5 x 52 / 56 x 45	8.5	40.5	135.0	80	Y480P2SS/W403DS
	125	32		95 x 70	75 x 52 / 72 x 45	9.0	39.0	161.0	100	Y580P1SS/W503DS
	125	32		77 x 67	61.5 x 52 / 56 x 45	8.5	39.0	161.0	100	Y580P2SS/W503DS
DB/α Dir. locking brake	100	32		95 x 70	75 x 52 / 72 x 45	9.0	40.5	135.0	80	Y480XDP1SS/W403DS
	100	32		77 x 67	61.5 x 52 / 56 x 45	8.5	40.5	135.0	80	Y480XDP2SS/W403DS
	125	32		95 x 70	75 x 52 / 72 x 45	9.0	39.0	161.0	100	Y580XDP1SS/W503DS
	125	32		77 x 67	61.5 x 52 / 56 x 45	8.5	39.0	161.0	100	Y580XDP2SS/W503DS
	200	32		95 x 70	75 x 52 / 72 x 45	9.0	57.5	235.0	120	Y880XDP1SS/W803UXS



Stainless steel

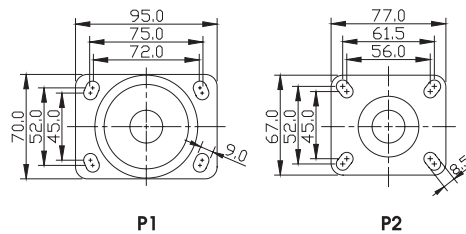

Pressed stainless steel double ballrace swivel yoke, electrolytic polishing finish



TB Total locking brake
Total Lock system locks both swivel head and wheel simultaneously for secure parking. Integrated ON/OFF Nylon brake pedals for easy and quiet operation.



DB Directional locking brake
Directional Lock permits free wheel rotation while swivel head remains locked, an easy way to keep equipment traveling straight. Integrated ON/OFF Nylon brake pedals for easy and quiet operation. Release pedal in green color.

P Top Plate Fitting

TPR-SS Wheel Plastic hub, grey color thermoplastic rubber tire

Brake type	mm	mm	mm	mm	mm	mm	mm	mm	kg	Code
Non-brake Free swivel	100	32		95 x 70	75 x 52 / 72 x 45	9.0	40.5	135.0	80	Y481P1SS/W403DS
	100	32		77 x 67	61.5 x 52 / 56 x 45	8.5	40.5	135.0	80	Y481P2SS/W403DS
	100	32		105 x 80	85 x 60 / 75 x 60	10.0	40.5	135.0	80	Y481P3SS/W403DS
	125	32		95 x 70	75 x 52 / 72 x 45	9.0	39.0	161.0	100	Y581P1SS/W503DS
	125	32		77 x 67	61.5 x 52 / 56 x 45	8.5	39.0	161.0	100	Y581P2SS/W503DS
	125	32		105 x 80	85 x 60 / 75 x 60	10.0	39.0	161.0	100	Y581P3SS/W503DS
	200	32		95 x 70	75 x 52 / 72 x 45	9.0	57.5	235.0	120	Y881P1SS/W803UXS



Brake type	mm	mm	mm	mm	mm	mm	mm	kg	Code
Non-brake Fixed	100	32		95 x 77	75 x 52 / 72 x 45	9.0	135.0	80	Y482P1SS/W403DS
	125	32		95 x 77	75 x 52 / 72 x 45	9.0	161.0	100	Y582P1SS/W503DS
	100	32		67 x 77	52 x 61.5 / 45 x 56	8.5	135.0	80	Y485P2SS/W403DS
	125	32		67 x 77	52 x 61.5 / 45 x 56	8.5	161.0	100	Y585P2SS/W503DS



TPR-SS/AS Wheel Conductive wheels are also available

Plastic hub, grey color conductive thermoplastic rubber tire, stainless steel ball bearings, stainless steel threadguards

	Code
100 x 32mm	W403DS-AS
125 x 32mm	W503DS-AS



Electrical Resistance $\leq 10^4 \Omega$

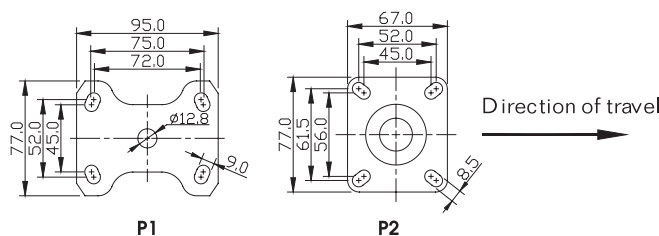



TB/B Total locking brake
 Total Lock system simultaneously locks both swivel head and wheel for a secure parking.
 Zinc-alloy brake pedal.

P Top Plate Fitting

TPU-SS Wheel Plastic hub, grey color polyurethane tire

Brake type	mm	mm		mm	mm	mm	mm	mm	mm	kg	Code
TB/B Total locking brake	75	32		95 x 70	75 x 52 / 72 x 45	9.0	33.0	107.0	50		Y380XP1SS/W300S
	75	32		77 x 67	61.5 x 52 / 56 x 45	8.5	33.0	107.0	50		Y380XP2SS/W300S
	100	32		95 x 70	75 x 52 / 72 x 45	9.0	40.5	135.0	80		Y480XP1SS/W400DS
	100	32		77 x 67	61.5 x 52 / 56 x 45	8.5	40.5	135.0	80		Y480XP2SS/W400DS
	125	32		95 x 70	75 x 52 / 72 x 45	9.0	39.0	161.0	100		Y580XP1SS/W500DS
	125	32		77 x 67	61.5 x 52 / 56 x 45	8.5	39.0	161.0	100		Y580XP2SS/W500DS
	150	32		95 x 70	75 x 52 / 72 x 45	9.0	50.0	189.5	100		Y680XP1SS/W600DS
	150	32		77 x 67	61.5 x 52 / 56 x 45	8.5	50.0	189.5	100		Y680XP2SS/W600DS
TB/B Total locking brake	75	32		95 x 70	75 x 52 / 72 x 45	9.0	41.0	107.0	50		Y380P1SS/W300S
	75	32		77 x 67	61.5 x 52 / 56 x 45	8.5	41.0	107.0	50		Y380P2SS/W300S
	100	32		95 x 70	75 x 52 / 72 x 45	9.0	40.5	135.0	80		Y480P1SS/W400DS
	100	32		77 x 67	61.5 x 52 / 56 x 45	8.5	40.5	135.0	80		Y480P2SS/W400DS
	125	32		95 x 70	75 x 52 / 72 x 45	9.0	39.0	161.0	100		Y580P1SS/W500DS
	125	32		77 x 67	61.5 x 52 / 56 x 45	8.5	39.0	161.0	100		Y580P2SS/W500DS
	150	32		95 x 70	75 x 52 / 72 x 45	9.0	46.5	189.5	100		Y680P1SS/W600DS
	150	32		77 x 67	61.5 x 52 / 56 x 45	8.5	46.5	189.5	100		Y680P2SS/W600DS



Stainless steel

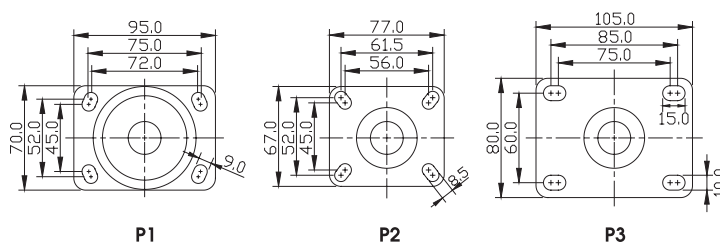

Pressed stainless steel double ballrace swivel yoke, electrolytic polishing finish



TB/ Total locking brake
Total Lock system locks both swivel head and wheel simultaneously for secure parking. Integrated ON/OFF Nylon brake pedals for easy and quiet operation.



DB/ Directional locking brake
Directional Lock permits free wheel rotation while swivel head remains locked, an easy way to keep equipment traveling straight. Integrated ON/OFF Nylon brake pedals for easy and quiet operation. Release pedal in green color.

P Top Plate Fitting

TPU-SS Wheel Plastic hub, grey color polyurethane tire

Brake type	mm	mm	mm	mm	mm	mm	mm	mm	kg	Code
DB/ Dir. locking brake	75	32		95 x 70	75 x 52 / 72 x 45	9.0	33.0	107.0	50	Y380XDP1SS/W300S
	75	32		77 x 67	61.5 x 52 / 56 x 45	8.5	33.0	107.0	50	Y380XDP2SS/W300S
	100	32		95 x 70	75 x 52 / 72 x 45	9.0	40.5	135.0	80	Y480XDP1SS/W400DS
	100	32		77 x 67	61.5 x 52 / 56 x 45	8.5	40.5	135.0	80	Y480XDP2SS/W400DS
	125	32		95 x 70	75 x 52 / 72 x 45	9.0	39.0	161.0	100	Y580XDP1SS/W500DS
	125	32		77 x 67	61.5 x 52 / 56 x 45	8.5	39.0	161.0	100	Y580XDP2SS/W500DS
	150	32		95 x 70	75 x 52 / 72 x 45	9.0	50.0	189.5	100	Y680XDP1SS/W600DS
	150	32		77 x 67	61.5 x 52 / 56 x 45	8.5	50.0	189.5	100	Y680XDP2SS/W600DS
Non-brake Free swivel	75	32		95 x 70	75 x 52 / 72 x 45	9.0	33.0	107.0	50	Y381P1SS/W300S
	75	32		77 x 67	61.5 x 52 / 56 x 45	8.5	33.0	107.0	50	Y381P2SS/W300S
	75	32		105 x 80	85 x 60 / 75 x 60	10.0	33.0	107.0	50	Y381P3SS/W300S
	100	32		95 x 70	75 x 52 / 72 x 45	9.0	40.5	135.0	80	Y481P1SS/W400DS
	100	32		77 x 67	61.5 x 52 / 56 x 45	8.5	40.5	135.0	80	Y481P2SS/W400DS
	100	32		105 x 80	85 x 60 / 75 x 60	10.0	40.5	135.0	80	Y481P3SS/W400DS
	125	32		95 x 70	75 x 52 / 72 x 45	9.0	39.0	161.0	100	Y581P1SS/W500DS
	125	32		77 x 67	61.5 x 52 / 56 x 45	8.5	39.0	161.0	100	Y581P2SS/W500DS
	125	32		105 x 80	85 x 60 / 75 x 60	10.0	39.0	161.0	100	Y581P3SS/W500DS
	150	32		95 x 70	75 x 52 / 72 x 45	9.0	50.0	189.5	100	Y681P1SS/W600DS
	150	32		77 x 67	61.5 x 52 / 56 x 45	8.5	50.0	189.5	100	Y681P2SS/W600DS
	150	32		105 x 80	85 x 60 / 75 x 60	10.0	50.0	189.5	100	Y681P3SS/W600DS

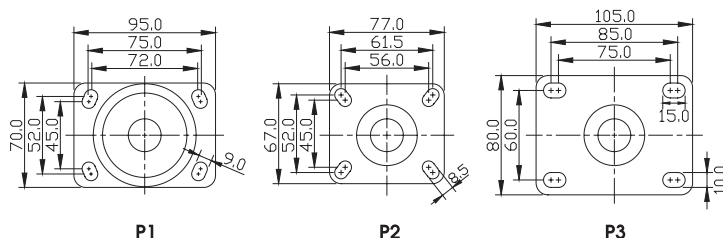

















TB Total locking brake
 Total Lock system simultaneously locks both swivel head and wheel for a secure parking.
 Zinc-alloy brake pedal.

P Top Plate Fitting

TPU-SS Wheel Plastic hub, grey color polyurethane tire

Brake type	 mm	 mm		 mm	 mm	 mm	 mm	 kg	Code
Non-brake Fixed	75	32		95 x 77	75 x 52 / 72 x 45	9.0	107.0	50	Y382P1SS/W300S
	100	32		95 x 77	75 x 52 / 72 x 45	9.0	135.0	80	Y482P1SS/W400DS
	125	32		95 x 77	75 x 52 / 72 x 45	9.0	161.0	100	Y582P1SS/W500DS
	150	32		95 x 77	75 x 52 / 72 x 45	9.0	189.5	100	Y682P1SS/W600DS
	75	32		67 x 77	52 x 61.5 / 45 x 56	8.5	107.0	50	Y385P2SS/W300S
	100	32		67 x 77	52 x 61.5 / 45 x 56	8.5	135.0	80	Y485P2SS/W400DS
	125	32		67 x 77	52 x 61.5 / 45 x 56	8.5	161.0	100	Y585P2SS/W500DS



 Stainless steel

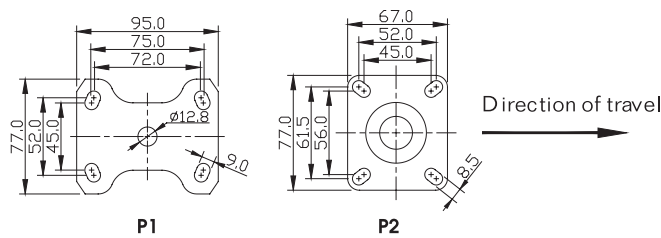

Pressed stainless steel double ballrace swivel yoke, electrolytic polishing finish



TB/A Total locking brake
Total Lock system locks both swivel head and wheel simultaneously for secure parking. Integrated ON/OFF Nylon brake pedals for easy and quiet operation.



DB/A Directional locking brake
Directional Lock permits free wheel rotation while swivel head remains locked, an easy way to keep equipment traveling straight. Integrated ON/OFF Nylon brake pedals for easy and quiet operation. Release pedal in green color.

P Top Plate Fitting



PM-SS Wheel

Solid nylon wheel, stainless steel roller bearing, stainless steel threadguards

Brake type	mm	mm		mm	mm	mm	mm	mm	mm	kg	Code
TB/A Total locking brake	75	32		95 x 70	75 x 52 / 72 x 45	9.0	33.0	107.0	50		Y380XP1SS/W309RXS
	75	32		77 x 67	61.5 x 52 / 56 x 45	8.5	33.0	107.0	50		Y380XP2SS/W309RXS
	100	32		95 x 70	75 x 52 / 72 x 45	9.0	40.5	135.0	80		Y480XP1SS/W409RXS
	100	32		77 x 67	61.5 x 52 / 56 x 45	8.5	40.5	135.0	80		Y480XP2SS/W409RXS
	125	32		95 x 70	75 x 52 / 72 x 45	9.0	39.0	161.0	100		Y580XP1SS/W509RXS
	125	32		77 x 67	61.5 x 52 / 56 x 45	8.5	39.0	161.0	100		Y580XP2SS/W509RXS
TB/B Total locking brake	75	32		95 x 70	75 x 52 / 72 x 45	9.0	41.0	107.0	50		Y380P1SS/W309RXS
	75	32		77 x 67	61.5 x 52 / 56 x 45	8.5	41.0	107.0	50		Y380P2SS/W309RXS
	100	32		95 x 70	75 x 52 / 72 x 45	9.0	40.5	135.0	80		Y480P1SS/W409RXS
	100	32		77 x 67	61.5 x 52 / 56 x 45	8.5	40.5	135.0	80		Y480P2SS/W409RXS
	125	32		95 x 70	75 x 52 / 72 x 45	9.0	39.0	161.0	100		Y580P1SS/W509RXS
	125	32		77 x 67	61.5 x 52 / 56 x 45	8.5	39.0	161.0	100		Y580P2SS/W509RXS
DB/A Dir. locking brake	75	32		95 x 70	75 x 52 / 72 x 45	9.0	33.0	107.0	50		Y380XDP1SS/W309RXS
	75	32		77 x 67	61.5 x 52 / 56 x 45	8.5	33.0	107.0	50		Y380XDP2SS/W309RXS
	100	32		95 x 70	75 x 52 / 72 x 45	9.0	40.5	135.0	80		Y480XDP1SS/W409RXS
	100	32		77 x 67	61.5 x 52 / 56 x 45	8.5	40.5	135.0	80		Y480XDP2SS/W409RXS
	125	32		95 x 70	75 x 52 / 72 x 45	9.0	39.0	161.0	100		Y580XDP1SS/W509RXS
	125	32		77 x 67	61.5 x 52 / 56 x 45	8.5	39.0	161.0	100		Y580XDP2SS/W509RXS

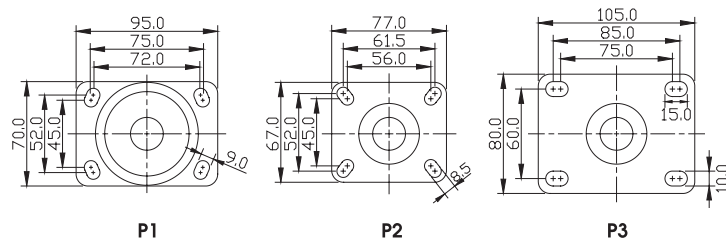



TB Total locking brake
 Total Lock system simultaneously locks both swivel head and wheel for a secure parking.
 Zinc-alloy brake pedal.

P Top Plate Fitting



PM-SS Wheel

Solid nylon wheel, stainless steel roller bearing, stainless steel threadguards

Brake type	mm	mm	mm	mm	mm	mm	mm	mm	kg	Code
Non-brake Free swivel	75	32		95 x 70	75 x 52 / 72 x 45	9.0	33.0	107.0	50	Y381P1SS/W309RXS
	75	32		77 x 67	61.5 x 52 / 56 x 45	8.5	33.0	107.0	50	Y381P2SS/W309RXS
	75	32		105 x 80	85 x 60 / 75 x 60	10.0	33.0	107.0	50	Y381P3SS/W309RXS
	100	32		95 x 70	75 x 52 / 72 x 45	9.0	40.5	135.0	80	Y481P1SS/W409RXS
	100	32		77 x 67	61.5 x 52 / 56 x 45	8.5	40.5	135.0	80	Y481P2SS/W409RXS
	100	32		105 x 80	85 x 60 / 75 x 60	10.0	40.5	135.0	80	Y481P3SS/W409RXS
	125	32		95 x 70	75 x 52 / 72 x 45	9.0	39.0	161.0	100	Y581P1SS/W509RXS
	125	32		77 x 67	61.5 x 52 / 56 x 45	8.5	39.0	161.0	100	Y581P2SS/W509RXS
	125	32		105 x 80	85 x 60 / 75 x 60	10.0	39.0	161.0	100	Y581P3SS/W509RXS



Brake type	mm	mm	mm	mm	mm	mm	mm	kg	Code
Non-brake Fixed	75	32		95 x 77	75 x 52 / 72 x 45	9.0	107.0	50	Y382P1SS/W309RXS
	100	32		95 x 77	75 x 52 / 72 x 45	9.0	135.0	80	Y482P1SS/W409RXS
	125	32		95 x 77	75 x 52 / 72 x 45	9.0	161.0	100	Y582P1SS/W509RXS
Non-brake Fixed	75	32		67 x 77	52 x 61.5 / 45 x 56	8.5	107.0	50	Y385P2SS/W309RXS
	100	32		67 x 77	52 x 61.5 / 45 x 56	8.5	135.0	80	Y485P2SS/W409RXS
	125	32		67 x 77	52 x 61.5 / 45 x 56	8.5	161.0	100	Y585P2SS/W509RXS



Stainless steel

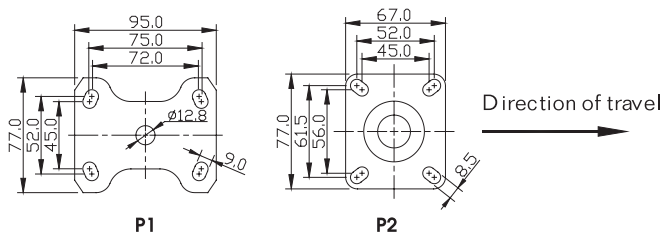

SC

Superior Castors

Application:
Stretcher trolleys;
general institution applications.

Size Available:
125x32, 150x32, 200x32mm

The SC is an enduring, sturdy castor, capable to handle fast and jerky movements.

When life dependency of patient is counted on speedy transfer for medical treatment, it requires stretcher trolleys armed with our Superior Castors. Likewise, it is equally important for the comfort of patient while transporting back and forth on stretcher trolley between wards.

Precision ball bearings at the swivel head and wheel axle always make turning and rolling easy. Tight fitting thread guards reduce chances for dirt and lint collected at the axle and slow down wheel rotation.

Undoubtedly, when it comes to efficient, economical, and dependable, this is your castor of choice.

SC SAVES!

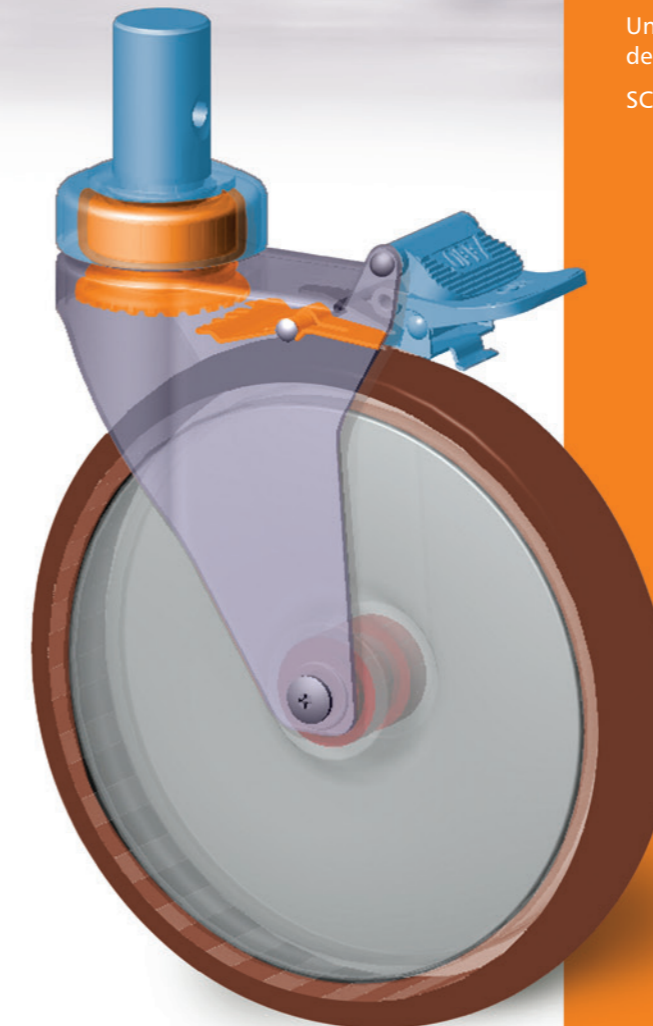

Pressed steel yoke, precision ball bearing swivel head, zinc-chromatized finish

Option: Bright chrome plated finish is also available, add suffix "-CR" to Catis code, e.g. YZ580XP1/W503U-CR



TB/A Total locking brake

Total Lock system locks both swivel head and wheel simultaneously for secure parking. Integrated ON/OFF Nylon brake pedals for easy and quiet operation.



DB/A Directional locking brake

Directional Lock permits free wheel rotation while swivel head remains locked, an easy way to keep equipment traveling straight. Integrated ON/OFF Nylon brake pedals for easy and quiet operation. Release pedal in green color.

P Top Plate Fitting



TPR Wheel

Plastic hub, grey color thermoplastic rubber tire

Brake type	mm	mm	mm	mm	mm	mm	mm	mm	kg	Code
TB/A Total locking brake	125	32		95 x 70	75 x 52 / 72 x 45	9.0	39.0	164.0	100	YZ580XP1/W503U
	150	32		95 x 70	75 x 52 / 72 x 45	9.0	50.0	192.5	120	YZ680XP1/W603U
	200	32		95 x 70	75 x 52 / 72 x 45	9.0	57.5	240.0	120	YZ880XP1/W803UX
DB/A Dir. locking brake	125	32		95 x 70	75 x 52 / 72 x 45	9.0	39.0	164.0	100	YZ580XDP1/W503U
	150	32		95 x 70	75 x 52 / 72 x 45	9.0	50.0	192.5	120	YZ680XDP1/W603U
	200	32		95 x 70	75 x 52 / 72 x 45	9.0	57.5	240.0	120	YZ880XDP1/W803UX
Non-brake Free swivel	125	32		95 x 70	75 x 52 / 72 x 45	9.0	39.0	164.0	100	YZ581P1/W503U
	150	32		95 x 70	75 x 52 / 72 x 45	9.0	50.0	192.5	120	YZ681P1/W603U
	200	32		95 x 70	75 x 52 / 72 x 45	9.0	57.5	240.0	120	YZ881P1/W803UX



200mm (8") wheel is available with metal threadguards only

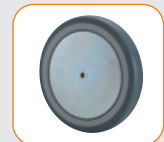

TPR/AS Wheel

Conductive wheels are also available

	Code
125 x 32mm	W503U-AS
150 x 32mm	W603U-AS
200 x 32mm	W803UX-AS*

Plastic hub and threadguards, grey color conductive thermoplastic rubber tire



*Wheel with metal threadguards (see P020)

Electrical Resistance $\leq 10^4 \Omega$

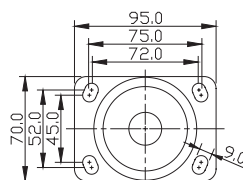

P Top Plate Fitting

TPU Wheel Plastic hub, grey color polyurethane tire

Brake type	mm	mm	mm	mm	mm	mm	mm	mm	kg	Code
TB/A Total locking brake	125	32		95 x 70	75 x 52 / 72 x 45	9.0	39.0	164.0	100	YZ580XP1/W500E
	150	32		95 x 70	75 x 52 / 72 x 45	9.0	50.0	192.5	120	YZ680XP1/W600E
DB/A Dir. locking brake	125	32		95 x 70	75 x 52 / 72 x 45	9.0	39.0	164.0	100	YZ580XDP1/W500E
	150	32		95 x 70	75 x 52 / 72 x 45	9.0	50.0	192.5	120	YZ680XDP1/W600E
Non-brake Free swivel	125	32		95 x 70	75 x 52 / 72 x 45	9.0	39.0	164.0	100	YZ581P1/W500E
	150	32		95 x 70	75 x 52 / 72 x 45	9.0	50.0	192.5	120	YZ681P1/W600E



ARB Wheel Al-alloy hub, grey color high elastic rubber tire

Brake type	mm	mm	mm	mm	mm	mm	mm	mm	kg	Code
TB/A Total locking brake	125	32		95 x 70	75 x 52 / 72 x 45	9.0	39.0	164.0	100	YZ580XP1/W529UX
	150	32		95 x 70	75 x 52 / 72 x 45	9.0	50.0	192.5	120	YZ680XP1/W629UX
	200	32		95 x 70	75 x 52 / 72 x 45	9.0	57.5	240.0	120	YZ880XP1/W829UX
DB/A Dir. locking brake	125	32		95 x 70	75 x 52 / 72 x 45	9.0	39.0	164.0	100	YZ580XDP1/W529UX
	150	32		95 x 70	75 x 52 / 72 x 45	9.0	50.0	192.5	120	YZ680XDP1/W629UX
	200	32		95 x 70	75 x 52 / 72 x 45	9.0	57.5	240.0	120	YZ880XDP1/W829UX
Non-brake Free swivel	125	32		95 x 70	75 x 52 / 72 x 45	9.0	39.0	164.0	100	YZ581P1/W529UX
	150	32		95 x 70	75 x 52 / 72 x 45	9.0	50.0	192.5	120	YZ681P1/W629UX
	200	32		95 x 70	75 x 52 / 72 x 45	9.0	57.5	240.0	120	YZ881P1/W829UX



Pressed steel yoke, precision ball bearing swivel head, zinc-chromatized finish

Option: Bright chrome plated finish is also available, add suffix "-CR" to Catis code, e.g. YZ580XP1/W503U-CR



TB Total locking brake

Total Lock system locks both swivel head and wheel simultaneously for secure parking. Integrated ON/OFF Nylon brake pedals for easy and quiet operation.



DB Directional locking brake

Directional Lock permits free wheel rotation while swivel head remains locked, an easy way to keep equipment traveling straight. Integrated ON/OFF Nylon brake pedals for easy and quiet operation. Release pedal in green color.

R Round Stem



TPR Wheel















Plastic hub, grey color thermoplastic rubber tire

Brake type	mm	mm		mm	mm	mm	mm	mm	mm	mm	kg	Code
TB Total locking brake	125	32		22.0	45.0	19.0	M8x1.25	39.0	164.0	100		YZ580XR8/W503U
	125	32		28.0	45.0	19.0	M8x1.25	39.0	164.0	100		YZ580XR9/W503U
	125	32		25.6	45.0	19.0	M8x1.25	39.0	164.0	100		YZ580XR16/W503U
	150	32		22.0	45.0	19.0	M8x1.25	50.0	192.5	120		YZ680XR8/W603U
	150	32		28.0	45.0	19.0	M8x1.25	50.0	192.5	120		YZ680XR9/W603U
	150	32		25.6	45.0	19.0	M8x1.25	50.0	192.5	120		YZ680XR16/W603U
	200	32		22.0	45.0	19.0	M8x1.25	57.5	240.0	120		YZ880XR8/W803UX
	200	32		28.0	45.0	19.0	M8x1.25	57.5	240.0	120		YZ880XR9/W803UX
	200	32		25.6	45.0	19.0	M8x1.25	57.5	240.0	120		YZ880XR16/W803UX
DB Dir. locking brake	125	32		22.0	45.0	19.0	M8x1.25	39.0	164.0	100		YZ580XDR8/W503U
	125	32		28.0	45.0	19.0	M8x1.25	39.0	164.0	100		YZ580XDR9/W503U
	125	32		25.6	45.0	19.0	M8x1.25	39.0	164.0	100		YZ580XDR16/W503U
	150	32		22.0	45.0	19.0	M8x1.25	50.0	192.5	120		YZ680XDR8/W603U
	150	32		28.0	45.0	19.0	M8x1.25	50.0	192.5	120		YZ680XDR9/W603U
	150	32		25.6	45.0	19.0	M8x1.25	50.0	192.5	120		YZ680XDR16/W603U
	200	32		22.0	45.0	19.0	M8x1.25	57.5	240.0	120		YZ880XDR8/W803UX
	200	32		28.0	45.0	19.0	M8x1.25	57.5	240.0	120		YZ880XDR9/W803UX
	200	32		25.6	45.0	19.0	M8x1.25	57.5	240.0	120		YZ880XDR16/W803UX



R Round Stem

TPR Wheel Plastic hub, grey color thermoplastic rubber tire

Brake type	 mm	 mm		 mm	 mm	 mm	 mm	 mm	 mm	 mm	 kg	Code
Non-brake Free swivel	125	32		22.0	45.0	19.0	M8x1.25	39.0	164.0	100		YZ581R8/W503U
	125	32		28.0	45.0	19.0	M8x1.25	39.0	164.0	100		YZ581R9/W503U
	125	32		25.6	45.0	19.0	M8x1.25	39.0	164.0	100		YZ581R16/W503U
	150	32		22.0	45.0	19.0	M8x1.25	50.0	192.5	120		YZ681R8/W603U
	150	32		28.0	45.0	19.0	M8x1.25	50.0	192.5	120		YZ681R9/W603U
	150	32		25.6	45.0	19.0	M8x1.25	50.0	192.5	120		YZ681R16/W603U
	200	32		22.0	45.0	19.0	M8x1.25	57.5	240.0	120		YZ881R8/W803UX
	200	32		28.0	45.0	19.0	M8x1.25	57.5	240.0	120		YZ881R9/W803UX
	200	32		25.6	45.0	19.0	M8x1.25	57.5	240.0	120		YZ881R16/W803UX



200mm (8") wheel is available with metal threadguards only



TPR/AS Wheel Conductive wheels are also available

	Code
Plastic hub and threadguards, grey color conductive thermoplastic rubber tire	125 x 32mm W503U-AS
	150 x 32mm W603U-AS
	200 x 32mm W803UX-AS*



*Wheel with metal threadguards (see P020)

Electrical Resistance $\leq 10^4 \Omega$

Pressed steel yoke, precision ball bearing swivel head, zinc-chromatized finish

Option: Bright chrome plated finish is also available, add suffix "-CR" to Catis code, e.g. YZ580XP1/W503U-CR



TB/A Total locking brake

Total Lock system locks both swivel head and wheel simultaneously for secure parking. Integrated ON/OFF Nylon brake pedals for easy and quiet operation.



DB/A Directional locking brake

Directional Lock permits free wheel rotation while swivel head remains locked, an easy way to keep equipment traveling straight. Integrated ON/OFF Nylon brake pedals for easy and quiet operation. Release pedal in green color.

R Round Stem



TPU Wheel Plastic hub, grey color polyurethane tire

Brake type	mm	mm									kg	Code
TB/A Total locking brake	125	32		22.0	45.0	19.0	M8x1.25	39.0	164.0	100		YZ580XR8/W500E
	125	32		28.0	45.0	19.0	M8x1.25	39.0	164.0	100		YZ580XR9/W500E
	125	32		25.6	45.0	19.0	M8x1.25	39.0	164.0	100		YZ580XR16/W500E
	150	32		22.0	45.0	19.0	M8x1.25	50.0	192.5	120		YZ680XR8/W600E
	150	32		28.0	45.0	19.0	M8x1.25	50.0	192.5	120		YZ680XR9/W600E
	150	32		25.6	45.0	19.0	M8x1.25	50.0	192.5	120		YZ680XR16/W600E
DB/A Dir. locking brake	125	32		22.0	45.0	19.0	M8x1.25	39.0	164.0	100		YZ580XDR8/W500E
	125	32		28.0	45.0	19.0	M8x1.25	39.0	164.0	100		YZ580XDR9/W500E
	125	32		25.6	45.0	19.0	M8x1.25	39.0	164.0	100		YZ580XDR16/W500E
	150	32		22.0	45.0	19.0	M8x1.25	50.0	192.5	120		YZ680XDR8/W600E
	150	32		28.0	45.0	19.0	M8x1.25	50.0	192.5	120		YZ680XDR9/W600E
	150	32		25.6	45.0	19.0	M8x1.25	50.0	192.5	120		YZ680XDR16/W600E
Non-brake Free swivel	125	32		22.0	45.0	19.0	M8x1.25	39.0	164.0	100		YZ581R8/W500E
	125	32		28.0	45.0	19.0	M8x1.25	39.0	164.0	100		YZ581R9/W500E
	125	32		25.6	45.0	19.0	M8x1.25	39.0	164.0	100		YZ581R16/W500E
	150	32		22.0	45.0	19.0	M8x1.25	50.0	192.5	120		YZ681R8/W600E
	150	32		28.0	45.0	19.0	M8x1.25	50.0	192.5	120		YZ681R9/W600E
	150	32		25.6	45.0	19.0	M8x1.25	50.0	192.5	120		YZ681R16/W600E



R Round Stem

ARB Wheel Al-alloy hub, grey color high elastic rubber tire

Brake type	mm	mm		mm	mm	mm	mm	mm	mm	mm	kg	Code
TB/A Total locking brake	125	32		22.0	45.0	19.0	M8x1.25	39.0	164.0	100		YZ580XR8/W529UX
	125	32		28.0	45.0	19.0	M8x1.25	39.0	164.0	100		YZ580XR9/W529UX
	125	32		25.6	45.0	19.0	M8x1.25	39.0	164.0	100		YZ580XR16/W529UX
	150	32		22.0	45.0	19.0	M8x1.25	50.0	192.5	120		YZ680XR8/W629UX
	150	32		28.0	45.0	19.0	M8x1.25	50.0	192.5	120		YZ680XR9/W629UX
	150	32		25.6	45.0	19.0	M8x1.25	50.0	192.5	120		YZ680XR16/W629UX
	200	32		22.0	45.0	19.0	M8x1.25	57.5	240.0	120		YZ880XR8/W829UX
	200	32		28.0	45.0	19.0	M8x1.25	57.5	240.0	120		YZ880XR9/W829UX
	200	32		25.6	45.0	19.0	M8x1.25	57.5	240.0	120		YZ880XR16/W829UX
DB/A Dir. locking brake	125	32		22.0	45.0	19.0	M8x1.25	39.0	164.0	100		YZ580XDR8/W529UX
	125	32		28.0	45.0	19.0	M8x1.25	39.0	164.0	100		YZ580XDR9/W529UX
	125	32		25.6	45.0	19.0	M8x1.25	39.0	164.0	100		YZ580XDR16/W529UX
	150	32		22.0	45.0	19.0	M8x1.25	50.0	192.5	120		YZ680XDR8/W629UX
	150	32		28.0	45.0	19.0	M8x1.25	50.0	192.5	120		YZ680XDR9/W629UX
	150	32		25.6	45.0	19.0	M8x1.25	50.0	192.5	120		YZ680XDR16/W629UX
	200	32		22.0	45.0	19.0	M8x1.25	57.5	240.0	120		YZ880XDR8/W829UX
	200	32		28.0	45.0	19.0	M8x1.25	57.5	240.0	120		YZ880XDR9/W829UX
	200	32		25.6	45.0	19.0	M8x1.25	57.5	240.0	120		YZ880XDR16/W829UX
Non-brake Free swivel	125	32		22.0	45.0	19.0	M8x1.25	39.0	164.0	100		YZ581R8/W529UX
	125	32		28.0	45.0	19.0	M8x1.25	39.0	164.0	100		YZ581R9/W529UX
	125	32		25.6	45.0	19.0	M8x1.25	39.0	164.0	100		YZ581R16/W529UX
	150	32		22.0	45.0	19.0	M8x1.25	50.0	192.5	120		YZ681R8/W629UX
	150	32		28.0	45.0	19.0	M8x1.25	50.0	192.5	120		YZ681R9/W629UX
	150	32		25.6	45.0	19.0	M8x1.25	50.0	192.5	120		YZ681R16/W629UX
	200	32		22.0	45.0	19.0	M8x1.25	57.5	240.0	120		YZ881R8/W829UX
	200	32		28.0	45.0	19.0	M8x1.25	57.5	240.0	120		YZ881R9/W829UX
	200	32		25.6	45.0	19.0	M8x1.25	57.5	240.0	120		YZ881R16/W829UX



Pressed steel yoke, precision ball bearing swivel head, zinc-chromatized finish

Option: Bright chrome plated finish is also available, add suffix "-CR" to Catis code, e.g. YZ580XP1/W503U-CR



TB Total locking brake

Total Lock system locks both swivel head and wheel simultaneously for secure parking. Integrated ON/OFF Nylon brake pedals for easy and quiet operation.



DB Directional locking brake





















Directional Lock permits free wheel rotation while swivel head remains locked, an easy way to keep equipment traveling straight. Integrated ON/OFF Nylon brake pedals for easy and quiet operation. Release pedal in green color.

T Threaded Stem Fitting with Hex Base Washer



TPR Wheel















Plastic hub, grey color thermoplastic rubber tire

Brake type	 mm	 mm		 mm	 mm	 mm	 mm	 kg	Code
TB Total locking brake	125	32		1/2-13UNC	1"	39.0	164.0	100	YZ580XT2/W503U
	125	32		M12 P1.75	25.0	39.0	164.0	100	YZ580XT4/W503U
	125	32		M16 P2.0	25.0	39.0	164.0	100	YZ580XT5/W503U
	125	32		1/2-20UNF	25.0	39.0	164.0	100	YZ580XT10/W503U
	150	32		1/2-13UNC	1"	50.0	192.5	120	YZ680XT2/W603U
	150	32		M12 P1.75	25.0	50.0	192.5	120	YZ680XT4/W603U
	150	32		M16 P2.0	25.0	50.0	192.5	120	YZ680XT5/W603U
	150	32		1/2-20UNF	25.0	50.0	192.5	120	YZ680XT10/W603U
	200	32		1/2-13UNC	1"	57.5	240.0	120	YZ880XT2/W803UX
	200	32		M12 P1.75	25.0	57.5	240.0	120	YZ880XT4/W803UX
	200	32		M16 P2.0	25.0	57.5	240.0	120	YZ880XT5/W803UX
	200	32		1/2-20UNF	25.0	57.5	240.0	120	YZ880XT10/W803UX



T Threaded Stem Fitting with Hex Base Washer

TPR Wheel Plastic hub, grey color thermoplastic rubber tire

Brake type	 mm	 mm		 mm	 mm	 mm	 mm	 kg	Code
Non-brake Free swivel	125	32		1/2-13UNC	1"	39.0	164.0	100	YZ581T2/W503U
	125	32		M12 P1.75	25.0	39.0	164.0	100	YZ581T4/W503U
	125	32		M16 P2.0	25.0	39.0	164.0	100	YZ581T5/W503U
	125	32		1/2-20UNF	25.0	39.0	164.0	100	YZ581T10/W503U
	150	32		1/2-13UNC	1"	50.0	192.5	120	YZ681T2/W603U
	150	32		M12 P1.75	25.0	50.0	192.5	120	YZ681T4/W603U
	150	32		M16 P2.0	25.0	50.0	192.5	120	YZ681T5/W603U
	150	32		1/2-20UNF	25.0	50.0	192.5	120	YZ681T10/W603U
	200	32		1/2-13UNC	1"	57.5	240.0	120	YZ881T2/W803UX
	200	32		M12 P1.75	25.0	57.5	240.0	120	YZ881T4/W803UX
	200	32		M16 P2.0	25.0	57.5	240.0	120	YZ881T5/W803UX
	200	32		1/2-20UNF	25.0	57.5	240.0	120	YZ881T10/W803UX



200mm (8") wheel is available with metal threadguards only



TPR/AS Wheel Conductive wheels are also available

	Code
Plastic hub and threadguards, grey color conductive thermoplastic rubber tire	125 x 32mm W503U-AS
	150 x 32mm W603U-AS
	200 x 32mm W803UX-AS*



*Wheel with metal threadguards (see P020)

Electrical Resistance $\leq 10^4 \Omega$

Pressed steel yoke, precision ball bearing swivel head, zinc-chromatized finish

Option: Bright chrome plated finish is also available, add suffix "-CR" to Catis code, e.g. YZ580XP1/W503U-CR



TBA Total locking brake

Total Lock system locks both swivel head and wheel simultaneously for secure parking. Integrated ON/OFF Nylon brake pedals for easy and quiet operation.



DBA Directional locking brake

Directional Lock permits free wheel rotation while swivel head remains locked, an easy way to keep equipment traveling straight. Integrated ON/OFF Nylon brake pedals for easy and quiet operation. Release pedal in green color.

T Threaded Stem Fitting with Hex Base Washer



TPU Wheel Plastic hub, grey color polyurethane tire

































Brake type	 mm	 mm		 mm	 mm	 mm	 mm	 kg	Code
TBA Total locking brake	125	32		1/2-13UNC	1"	39.0	164.0	100	YZ580XT2/W500E
	125	32		M12 P1.75	25.0	39.0	164.0	100	YZ580XT4/W500E
	125	32		M16 P2.0	25.0	39.0	164.0	100	YZ580XT5/W500E
	125	32		1/2-20UNF	25.0	39.0	164.0	100	YZ580XT10/W500E
	150	32		1/2-13UNC	1"	50.0	192.5	120	YZ680XT2/W600E
	150	32		M12 P1.75	25.0	50.0	192.5	120	YZ680XT4/W600E
	150	32		M16 P2.0	25.0	50.0	192.5	120	YZ680XT5/W600E
	150	32		1/2-20UNF	25.0	50.0	192.5	120	YZ680XT10/W600E
Non-brake Free swivel	125	32		1/2-13UNC	1"	39.0	164.0	100	YZ581T2/W500E
	125	32		M12 P1.75	25.0	39.0	164.0	100	YZ581T4/W500E
	125	32		M16 P2.0	25.0	39.0	164.0	100	YZ581T5/W500E
	125	32		1/2-20UNF	25.0	39.0	164.0	100	YZ581T10/W500E
	150	32		1/2-13UNC	1"	50.0	192.5	120	YZ681T2/W600E
	150	32		M12 P1.75	25.0	50.0	192.5	120	YZ681T4/W600E
	150	32		M16 P2.0	25.0	50.0	192.5	120	YZ681T5/W600E
	150	32		1/2-20UNF	25.0	50.0	192.5	120	YZ681T10/W600E



T Threaded Stem Fitting with Hex Base Washer



ARB Wheel Al-alloy hub, grey color high elastic rubber tire

Brake type	 mm	 mm		 mm	 mm	 mm	 mm	 kg	Code
 Total locking brake	125	32		1/2-13UNC	1"	39.0	164.0	100	YZ580XT2/W529UX
	125	32		M12 P1.75	25.0	39.0	164.0	100	YZ580XT4/W529UX
	125	32		M16 P2.0	25.0	39.0	164.0	100	YZ580XT5/W529UX
	125	32		1/2-20UNF	25.0	39.0	164.0	100	YZ580XT10/W529UX
	150	32		1/2-13UNC	1"	50.0	192.5	120	YZ680XT2/W629UX
	150	32		M12 P1.75	25.0	50.0	192.5	120	YZ680XT4/W629UX
	150	32		M16 P2.0	25.0	50.0	192.5	120	YZ680XT5/W629UX
	150	32		1/2-20UNF	25.0	50.0	192.5	120	YZ680XT10/W629UX
	200	32		1/2-13UNC	1"	57.5	240.0	120	YZ880XT2/W829UX
	200	32		M12 P1.75	25.0	57.5	240.0	120	YZ880XT4/W829UX
	200	32		M16 P2.0	25.0	57.5	240.0	120	YZ880XT5/W829UX
	200	32		1/2-20UNF	25.0	57.5	240.0	120	YZ880XT10/W829UX
Non-brake Free swivel	125	32		1/2-13UNC	1"	39.0	164.0	100	YZ581T2/W529UX
	125	32		M12 P1.75	25.0	39.0	164.0	100	YZ581T4/W529UX
	125	32		M16 P2.0	25.0	39.0	164.0	100	YZ581T5/W529UX
	125	32		1/2-20UNF	25.0	39.0	164.0	100	YZ581T10/W529UX
	150	32		1/2-13UNC	1"	50.0	192.5	120	YZ681T2/W629UX
	150	32		M12 P1.75	25.0	50.0	192.5	120	YZ681T4/W629UX
	150	32		M16 P2.0	25.0	50.0	192.5	120	YZ681T5/W629UX
	150	32		1/2-20UNF	25.0	50.0	192.5	120	YZ681T10/W629UX
	200	32		1/2-13UNC	1"	57.5	240.0	120	YZ881T2/W829UX
	200	32		M12 P1.75	25.0	57.5	240.0	120	YZ881T4/W829UX
	200	32		M16 P2.0	25.0	57.5	240.0	120	YZ881T5/W829UX
	200	32		1/2-20UNF	25.0	57.5	240.0	120	YZ881T10/W829UX



In the business of health care and medical practice, patient comfort is one of the elements considered vital for recovery. The ease with which medical personnel can move medical equipments, and transport patients to and fro is equally important to the wellness of the patients.

Our Central Locking Bed Castors fulfill all criteria prerequisite of first class health care system. Besides easy to install and operate, they are quiet in motion, less machine-like and obtrusive, portraying a more relax atmosphere to the hospital environment.

CL

Central Locking Bed Castors

Application:
Castors for home care and hospital beds.

Size Available:
100x32, 125x32, 150x32, 200x32mm

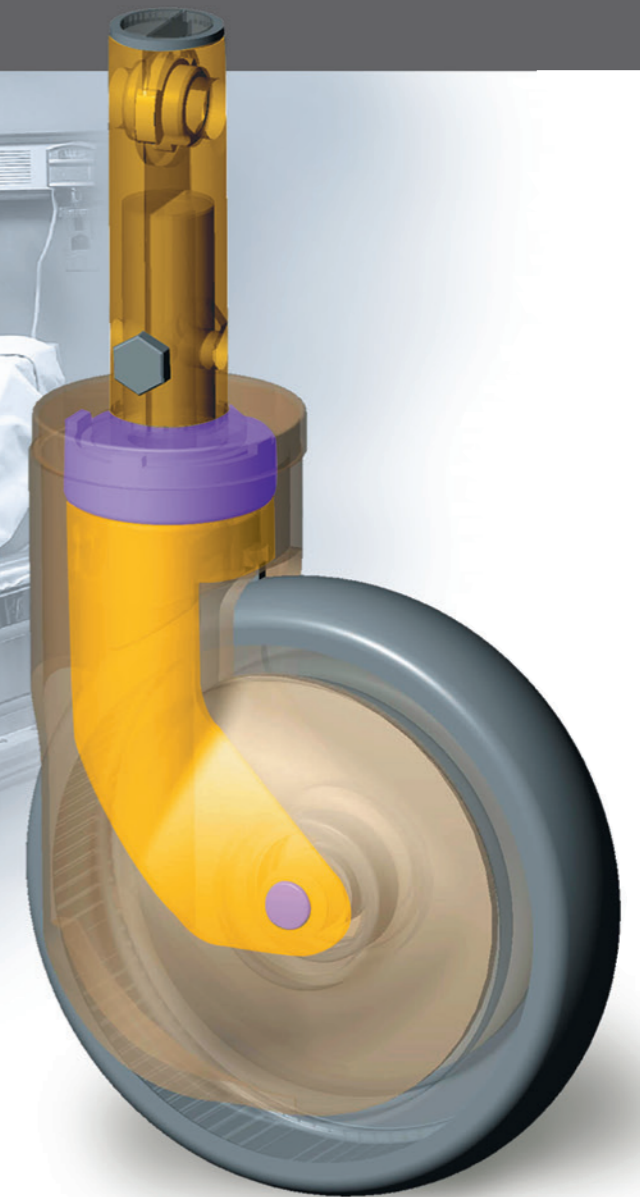
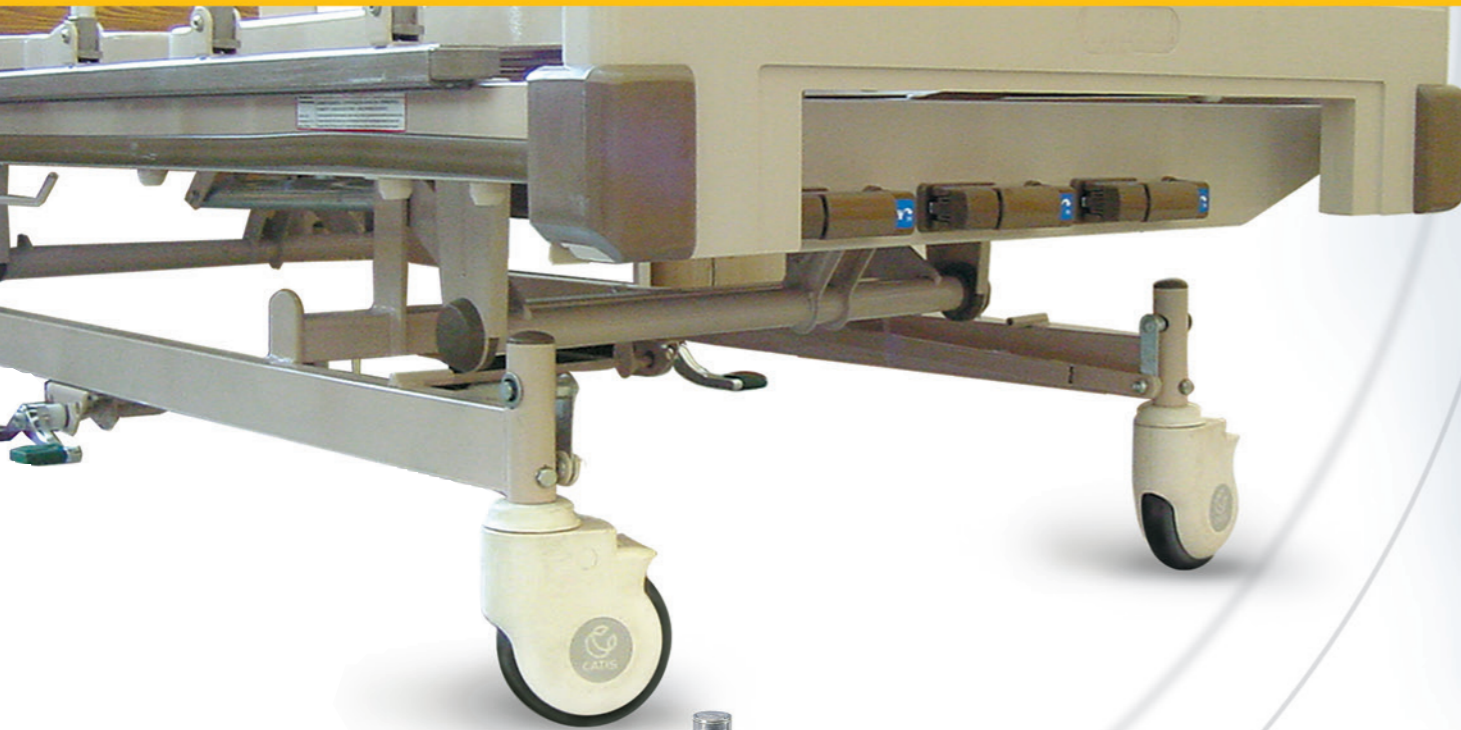

Pressed steel yoke with precision ball bearing swivel head, zinc-chromatized plating or powder coating finish available



CLB Central locking brake
Various locking functions actuated by means of different cam position, interconnected by hex rod and change lever.

Stem size
Ø 28x98.5, 45°x2

Types available
A Total lock / Free / Dir. lock
B Total lock / Free
C Dir. lock / Free
D Free swivel



TPR Wheel Plastic hub, grey color thermoplastic rubber tire

Brake type	mm	mm		mm	mm	mm	mm	mm	mm	mm	kg	Code
A Total lock / Free / Dir. lock	125	32		28.0	98.5	19.0	M8x1.25	39.0	164.0	100		Y520R99/W503
	125	32		28.0	98.5	19.0	M8x1.25	39.0	164.0	100		Y520R99/W503U
	150	32		28.0	98.5	19.0	M8x1.25	50.0	192.5	120		Y620R99/W603U
	200	32		28.0	98.5	19.0	M8x1.25	57.5	240.0	120		Y820R99/W803UX
B Total lock / Free	125	32		28.0	98.5	19.0	M8x1.25	39.0	164.0	100		Y522R99/W503
	125	32		28.0	98.5	19.0	M8x1.25	39.0	164.0	100		Y522R99/W503U
	150	32		28.0	98.5	19.0	M8x1.25	50.0	192.5	120		Y622R99/W603U
	200	32		28.0	98.5	19.0	M8x1.25	57.5	240.0	120		Y822R99/W803UX
C Dir. lock / Free	125	32		28.0	98.5	19.0	M8x1.25	39.0	164.0	100		Y520DR99/W503
	125	32		28.0	98.5	19.0	M8x1.25	39.0	164.0	100		Y520DR99/W503U
	150	32		28.0	98.5	19.0	M8x1.25	50.0	192.5	120		Y620DR99/W603U
	200	32		28.0	98.5	19.0	M8x1.25	57.5	240.0	120		Y820DR99/W803UX
D Free swivel	125	32		28.0	45.0	19.0	M8x1.25	39.0	164.0	100		Y521R9/W503
	125	32		28.0	45.0	19.0	M8x1.25	39.0	164.0	100		Y521R9/W503U
	150	32		28.0	45.0	19.0	M8x1.25	50.0	192.5	120		Y621R9/W603U
	200	32		28.0	45.0	19.0	M8x1.25	57.5	240.0	120		Y821R9/W803UX



200mm (8") wheel is available with metal threadguards only





TPR/AS Wheel

Conductive wheels are also available

Plastic hub and threadguards, grey color conductive thermoplastic rubber tire

	Code
125 x 32mm	W503-AS
125 x 32mm	W503U-AS
150 x 32mm	W603U-AS
200 x 32mm	W803UX-AS*



* Wheel with metal threadguards (see P020)

Electrical Resistance $\leq 10^4 \Omega$



TPU Wheel

Plastic hub, grey color polyurethane tire

Brake type	mm	mm		mm	mm	mm	mm	mm	mm	mm	kg	Code
A Total lock / Free / Dir. lock	125	32		28.0	98.5	19.0	M8x1.25	39.0	164.0	100		Y520R99/W501E
	125	32		28.0	98.5	19.0	M8x1.25	39.0	164.0	100		Y520R99/W501UX*
	150	32		28.0	98.5	19.0	M8x1.25	50.0	192.5	120		Y620R99/W600E
B Total lock / Free	125	32		28.0	98.5	19.0	M8x1.25	39.0	164.0	100		Y522R99/W501E
	125	32		28.0	98.5	19.0	M8x1.25	39.0	164.0	100		Y522R99/W501UX*
	150	32		28.0	98.5	19.0	M8x1.25	50.0	192.5	120		Y622R99/W600E
C Dir. lock / Free	125	32		28.0	98.5	19.0	M8x1.25	39.0	164.0	100		Y520DR99/W501E
	125	32		28.0	98.5	19.0	M8x1.25	39.0	164.0	100		Y520DR99/W501UX*
	150	32		28.0	98.5	19.0	M8x1.25	50.0	192.5	120		Y620DR99/W600E
D Free swivel	125	32		28.0	45.0	19.0	M8x1.25	39.0	164.0	100		Y521R9/W501E
	125	32		28.0	45.0	19.0	M8x1.25	39.0	164.0	100		Y521R9/W501UX*
	150	32		28.0	45.0	19.0	M8x1.25	50.0	192.5	120		Y621R9/W600E



* Wheel with metal threadguards (see P014)

Options:

1. Metal threadguards available to all sizes, add suffix "X" to Catis code, e.g. Y520R99/W503 → Y520R99/W503X
2. Ivory color powder coating finish available to all size with metal threadguards only, add suffix "-IV" to Catis code, e.g. Y520R99/W503X → Y520R99/W503X-IV



Pressed steel yoke with precision ball bearing swivel head; aesthetic ABS cover, zinc-chromatized plating



CLB Central locking brake
Various locking functions actuated by means of different cam position, interconnected by hex rod and change lever.

Stem size
Ø 28x98.5, 45°x2

Types available
A Total lock / Free / Dir. lock
B Total lock / Free
C Dir. lock / Free
D Free swivel



TPR Wheel Plastic hub, grey color thermoplastic rubber tire

Brake type	mm	mm		mm	mm	mm	mm	mm	mm	mm	kg	Code
A Total lock / Free / Dir. lock	125	32		28.0	98.5	19.0	M8x1.25	39.0	164.0	100		DC520R99/W502
	125	32		28.0	98.5	19.0	M8x1.25	39.0	164.0	100		DC520R99/W502U
B Total lock / Free	125	32		28.0	98.5	19.0	M8x1.25	39.0	164.0	100		DC522R99/W502
	125	32		28.0	98.5	19.0	M8x1.25	39.0	164.0	100		DC522R99/W502U
C Dir. lock / Free	125	32		28.0	98.5	19.0	M8x1.25	39.0	164.0	100		DC520DR99/W502
	125	32		28.0	98.5	19.0	M8x1.25	39.0	164.0	100		DC520DR99/W502U
D Free swivel	125	32		28.0	45.0	19.0	M8x1.25	39.0	164.0	100		DC521R9/W502
	125	32		28.0	45.0	19.0	M8x1.25	39.0	164.0	100		DC521R9/W502U



TPR/AS Wheel Conductive wheels are also available

Add suffix "-AS" to Catis code, e.g. DC520R99/W502-AS
Electrical Resistance < 10⁴ Ω



TPU Wheel

Plastic hub, grey color polyurethane tire

Brake type	mm	mm		mm	mm	mm	mm	mm	mm	mm	kg	Code
A	125	32		28.0	98.5	19.0	M8x1.25	39.0	164.0	100		DC520R99/W501
Total lock / Free / Dir. lock	125	32		28.0	98.5	19.0	M8x1.25	39.0	164.0	100		DC520R99/W501U
B	125	32		28.0	98.5	19.0	M8x1.25	39.0	164.0	100		DC522R99/W501
Total lock / Free	125	32		28.0	98.5	19.0	M8x1.25	39.0	164.0	100		DC522R99/W501U
C	125	32		28.0	98.5	19.0	M8x1.25	39.0	164.0	100		DC520DR99/W501
Dir. lock / Free	125	32		28.0	98.5	19.0	M8x1.25	39.0	164.0	100		DC520DR99/W501U
D	125	32		28.0	45.0	19.0	M8x1.25	39.0	164.0	100		DC521R9/W501
Free swivel	125	32		28.0	45.0	19.0	M8x1.25	39.0	164.0	100		DC521R9/W501U



Pressed steel yoke with precision ball bearing swivel head; aesthetic ABS cover, zinc-chromatized plating

Option: Cam position with 30° actuating angle is available (see P148); to order, replace R99 with R66, e.g. Y690R99/W603U → Y690R66/W603U; same for free swivel, replace R9 with R69



CLB Central locking brake
Various locking functions actuated by means of different cam position, interconnected by hex rod and change lever.

Stem size
Ø 28x98.5, 45°x2
Ø 32x50.0, 30°x2

Types available
A Total lock / Free / Dir. lock
B Total lock / Free
C Dir. lock / Free
D Free swivel

TPR Wheel **Plastic hub, grey color thermoplastic rubber tire**

Brake type	mm	mm	mm	mm	mm	mm	mm	mm	mm	kg	Code	
A Total lock / Free / Dir. lock	100	32		28.0	98.5	19.0	M8x1.25	30.0	143.0	80	Y490R99/W403	
	125	32		28.0	98.5	19.0	M8x1.25	39.0	165.0	100	Y590R99/W503U	
	150	32		28.0	98.5	19.0	M8x1.25	40.0	189.0	120	Y690R99/W603U	
	200	32		28.0	98.5	19.0	M8x1.25	52.0	237.0	120	Y890R99/W803U	
B Total lock / Free	100	32		28.0	98.5	19.0	M8x1.25	30.0	143.0	80	Y492R99/W403	
	125	32		28.0	98.5	19.0	M8x1.25	39.0	165.0	100	Y592R99/W503U	
	150	32		28.0	98.5	19.0	M8x1.25	40.0	189.0	120	Y692R99/W603U	
	200	32		28.0	98.5	19.0	M8x1.25	52.0	237.0	120	Y892R99/W803U	
C Dir. lock / Free	100	32		28.0	98.5	19.0	M8x1.25	30.0	143.0	80	Y490DR99/W403	
	125	32		28.0	98.5	19.0	M8x1.25	39.0	165.0	100	Y590DR99/W503U	
	150	32		28.0	98.5	19.0	M8x1.25	40.0	189.0	120	Y690DR99/W603U	
	200	32		28.0	98.5	19.0	M8x1.25	52.0	237.0	120	Y890DR99/W803U	
D Free swivel	100	32		28.0	45.0	19.0	M8x1.25	30.0	143.0	80	Y491R9/W403	
	125	32		28.0	45.0	19.0	M8x1.25	39.0	165.0	100	Y591R9/W503U	
	150	32		28.0	45.0	19.0	M8x1.25	40.0	189.0	120	Y691R9/W603U	
	200	32		28.0	45.0	19.0	M8x1.25	52.0	237.0	120	Y891R9/W803U	

TPR/AS Wheel **Conductive wheels are also available**

Add suffix "-AS" to Catis code, e.g. DC520R99/W502-AS
Electrical Resistance < 10⁴ Ω

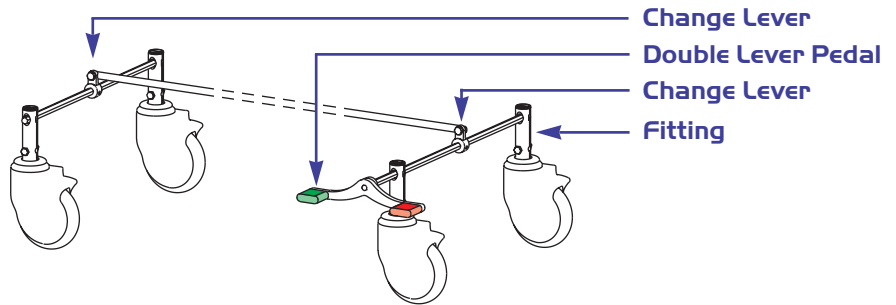

Change Lever

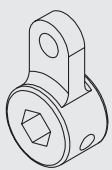

CV28
28mm
Change Lever
to transfer the function
to the second pair
of castors

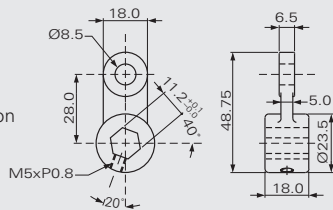

CV65
65mm
Change Lever
to transfer the function
to the second pair
of castors

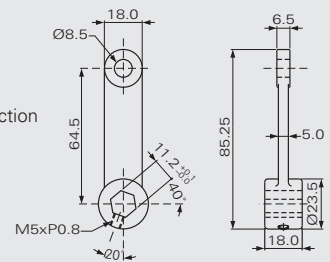

Double Lever Pedal

PD230

Al-Alloy pedal

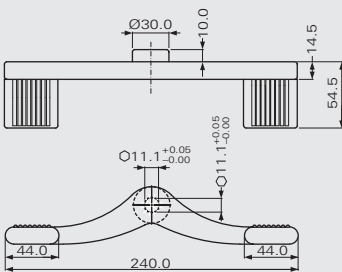

Cam Position

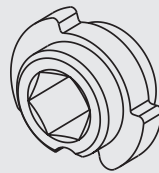

Cam Position
 α Actuating angle
R99 2x45°
R66 2x30°

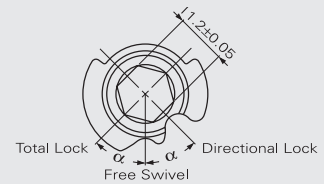

Fitting

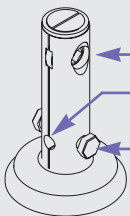

Cam hold
Fitting holes
Fitting bolt

α 2x45°

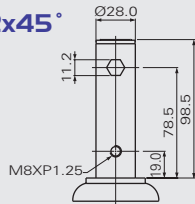

Fitting R99

Stem fitting for 28mm internal
tube diameter.
4xM8 threaded fitting holes at 90°
to each other for easy installation.
Cam hold 90° to direction of travel.

Fitting R9

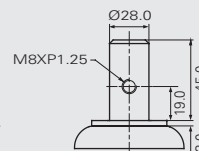

α 2x30°

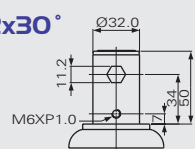

Fitting R66

Stem fitting for 32mm internal
tube diameter.
4xM6 threaded fitting holes at 90°
to each other for easy installation.
Cam hold 90° to direction of travel.

Fitting R69

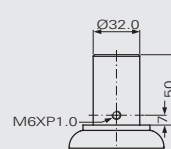

DC

Design Castors

Application:
General institution applications;
medical diagnostic machines.

Size Available:
100x25, 125x32mm

The DC is beautifully designed, and geared towards economical means.

It is especially suitable for general institution applications. And with ABS cover, it can be kept clean easily and adds to the environment a more conspicuous hygienic and aesthetic value.

When carts/trolleys demand quality and a human touch, our DC would be the best choice.

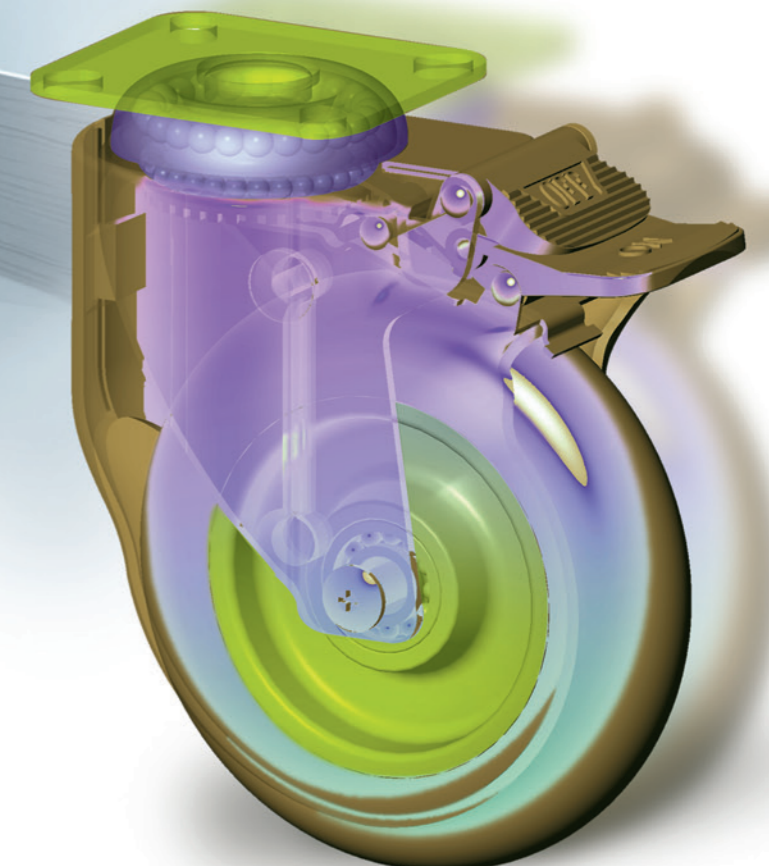

Pressed steel, zinc-chromatized double ballrace swivel yoke, aesthetic streamlined ABS covers



TB/A Total locking brake
Total Lock system locks both swivel head and wheel simultaneously for secure parking. Integrated ON/OFF Nylon brake pedals for easy and quiet operation.



DB/A Directional locking brake
Directional Lock permits free wheel rotation while swivel head remains locked, an easy way to keep equipment traveling straight. Integrated ON/OFF Nylon brake pedals for easy and quiet operation. Release pedal in green color.

P Top Plate Fitting





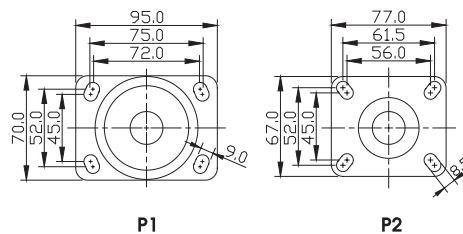







TPR Wheel Plastic hub, grey color thermoplastic rubber tire

Brake type	mm	mm	mm	mm	mm	mm	mm	mm	kg	Code
TB/A Total locking brake	100	25		95 x 70	75 x 52 / 72 x 45	9.0	38.5	135.0	60	DC100BP1/W412
	100	25		77 x 67	61.5 x 52 / 56 x 45	8.5	38.5	135.0	60	DC100BP2/W412
DB/A Dir. locking brake	125	32		95 x 70	75 x 52 / 72 x 45	9.0	39.0	161.0	100	DC125BP1/W502
	125	32		77 x 67	61.5 x 52 / 56 x 45	8.5	39.0	161.0	100	DC125BP2/W502
	125	32		95 x 70	75 x 52 / 72 x 45	9.0	39.0	161.0	100	DC125BP1/W502U
	125	32		77 x 67	61.5 x 52 / 56 x 45	8.5	39.0	161.0	100	DC125BP2/W502U
Non-brake Free swivel	125	32		95 x 70	75 x 52 / 72 x 45	9.0	39.0	161.0	100	DC125P1/W502
	125	32		77 x 67	61.5 x 52 / 56 x 45	8.5	39.0	161.0	100	DC125P2/W502
	125	32		95 x 70	75 x 52 / 72 x 45	9.0	39.0	161.0	100	DC125P1/W502U
	125	32		77 x 67	61.5 x 52 / 56 x 45	8.5	39.0	161.0	100	DC125P2/W502U









P Top Plate Fitting

TPU Wheel Plastic hub, grey color polyurethane tire

Brake type	mm	mm		mm	mm	mm	mm	mm	kg	Code
TB Total locking brake	125	32		95 x 70	75 x 52 / 72 x 45	9.0	39.0	161.0	100	DC125BP1/W501
	125	32		77 x 67	61.5 x 52 / 56 x 45	8.5	39.0	161.0	100	DC125BP2/W501
	125	32		95 x 70	75 x 52 / 72 x 45	9.0	39.0	161.0	100	DC125BP1/W501U
	125	32		77 x 67	61.5 x 52 / 56 x 45	8.5	39.0	161.0	100	DC125BP2/W501U
DB Dir. locking brake	125	32		95 x 70	75 x 52 / 72 x 45	9.0	39.0	161.0	100	DC125DBP1/W501
	125	32		77 x 67	61.5 x 52 / 56 x 45	8.5	39.0	161.0	100	DC125DBP2/W501
	125	32		95 x 70	75 x 52 / 72 x 45	9.0	39.0	161.0	100	DC125DBP1/W501U
	125	32		77 x 67	61.5 x 52 / 56 x 45	8.5	39.0	161.0	100	DC125DBP2/W501U
Non-brake Free swivel	125	32		95 x 70	75 x 52 / 72 x 45	9.0	39.0	161.0	100	DC125P1/W501
	125	32		77 x 67	61.5 x 52 / 56 x 45	8.5	39.0	161.0	100	DC125P2/W501
	125	32		95 x 70	75 x 52 / 72 x 45	9.0	39.0	161.0	100	DC125P1/W501U
	125	32		77 x 67	61.5 x 52 / 56 x 45	8.5	39.0	161.0	100	DC125P2/W501U



ARB Wheel Al-alloy hub, grey color high elastic rubber tire

Brake type	mm	mm		mm	mm	mm	mm	mm	kg	Code
TB Total locking brake	125	32		95 x 70	75 x 52 / 72 x 45	9.0	39.0	161.0	100	DC125BP1/W529U
	125	32		77 x 67	61.5 x 52 / 56 x 45	8.5	39.0	161.0	100	DC125BP2/W529U
DB Dir. locking brake	125	32		95 x 70	75 x 52 / 72 x 45	9.0	39.0	161.0	100	DC125DBP1/W529U
	125	32		77 x 67	61.5 x 52 / 56 x 45	8.5	39.0	161.0	100	DC125DBP2/W529U
Non-brake Free swivel	125	32		95 x 70	75 x 52 / 72 x 45	9.0	39.0	161.0	100	DC125P1/W529U
	125	32		77 x 67	61.5 x 52 / 56 x 45	8.5	39.0	161.0	100	DC125P2/W529U



Pressed steel, zinc-chromatized double ballrace swivel yoke, aesthetic streamlined ABS covers



TB/A Total locking brake
Total Lock system locks both swivel head and wheel simultaneously for secure parking. Integrated ON/OFF Nylon brake pedals for easy and quiet operation.



DB/A Directional locking brake
Directional Lock permits free wheel rotation while swivel head remains locked, an easy way to keep equipment traveling straight. Integrated ON/OFF Nylon brake pedals for easy and quiet operation. Release pedal in green color.

R Round Stem





















TPR Wheel Plastic hub, grey color thermoplastic rubber tire

Brake type	mm	mm		mm	mm	mm	mm	mm	mm	mm	kg	Code
TB/A Total locking brake	125	32		22.0	45.0	19.0	M8x1.25	39.0	161.0	100		DC125BR8/W502
	125	32		28.0	45.0	19.0	M8x1.25	39.0	161.0	100		DC125BR9/W502
	125	32		25.6	45.0	19.0	M8x1.25	39.0	161.0	100		DC125BR16/W502
	125	32		22.0	45.0	19.0	M8x1.25	39.0	161.0	100		DC125BR8/W502U
	125	32		28.0	45.0	19.0	M8x1.25	39.0	161.0	100		DC125BR9/W502U
	125	32		25.6	45.0	19.0	M8x1.25	39.0	161.0	100		DC125BR16/W502U
DB/A Dir. locking brake	125	32		22.0	45.0	19.0	M8x1.25	39.0	161.0	100		DC125DBR8/W502
	125	32		28.0	45.0	19.0	M8x1.25	39.0	161.0	100		DC125DBR9/W502
	125	32		25.6	45.0	19.0	M8x1.25	39.0	161.0	100		DC125DBR16/W502
	125	32		22.0	45.0	19.0	M8x1.25	39.0	161.0	100		DC125DBR8/W502U
	125	32		28.0	45.0	19.0	M8x1.25	39.0	161.0	100		DC125DBR9/W502U
	125	32		25.6	45.0	19.0	M8x1.25	39.0	161.0	100		DC125DBR16/W502U
Non-brake Free swivel	125	32		22.0	45.0	19.0	M8x1.25	39.0	161.0	100		DC125R8/W502
	125	32		28.0	45.0	19.0	M8x1.25	39.0	161.0	100		DC125R9/W502
	125	32		25.6	45.0	19.0	M8x1.25	39.0	161.0	100		DC125R16/W502
	125	32		22.0	45.0	19.0	M8x1.25	39.0	161.0	100		DC125R8/W502U
	125	32		28.0	45.0	19.0	M8x1.25	39.0	161.0	100		DC125R9/W502U
	125	32		25.6	45.0	19.0	M8x1.25	39.0	161.0	100		DC125R16/W502U



R Round Stem

TPU Wheel Plastic hub, grey color polyurethane tire

Brake type	mm	mm		mm	mm	mm	mm	mm	mm	mm	kg	Code
TB/A Total locking brake	125	32		22.0	45.0	19.0	M8x1.25	39.0	161.0	100	DC125BR8/W501	
	125	32		28.0	45.0	19.0	M8x1.25	39.0	161.0	100	DC125BR9/W501	
	125	32		25.6	45.0	19.0	M8x1.25	39.0	161.0	100	DC125BR16/W501	
	125	32		22.0	45.0	19.0	M8x1.25	39.0	161.0	100	DC125BR8/W501U	
	125	32		28.0	45.0	19.0	M8x1.25	39.0	161.0	100	DC125BR9/W501U	
	125	32		25.6	45.0	19.0	M8x1.25	39.0	161.0	100	DC125BR16/W501U	
DB/A Dir. locking brake	125	32		22.0	45.0	19.0	M8x1.25	39.0	161.0	100	DC125DBR8/W501	
	125	32		28.0	45.0	19.0	M8x1.25	39.0	161.0	100	DC125DBR9/W501	
	125	32		25.6	45.0	19.0	M8x1.25	39.0	161.0	100	DC125DBR16/W501	
	125	32		22.0	45.0	19.0	M8x1.25	39.0	161.0	100	DC125DBR8/W501U	
	125	32		28.0	45.0	19.0	M8x1.25	39.0	161.0	100	DC125DBR9/W501U	
	125	32		25.6	45.0	19.0	M8x1.25	39.0	161.0	100	DC125DBR16/W501U	
Non-brake Free swivel	125	32		22.0	45.0	19.0	M8x1.25	39.0	161.0	100	DC125R8/W501	
	125	32		28.0	45.0	19.0	M8x1.25	39.0	161.0	100	DC125R9/W501	
	125	32		25.6	45.0	19.0	M8x1.25	39.0	161.0	100	DC125R16/W501	
	125	32		22.0	45.0	19.0	M8x1.25	39.0	161.0	100	DC125R8/W501U	
	125	32		28.0	45.0	19.0	M8x1.25	39.0	161.0	100	DC125R9/W501U	
	125	32		25.6	45.0	19.0	M8x1.25	39.0	161.0	100	DC125R16/W501U	



Pressed steel, zinc-chromatized double ballrace swivel yoke, aesthetic streamlined ABS covers



TB Total locking brake
Total Lock system locks both swivel head and wheel simultaneously for secure parking. Integrated ON/OFF Nylon brake pedals for easy and quiet operation.



DB Directional locking brake
Directional Lock permits free wheel rotation while swivel head remains locked, an easy way to keep equipment traveling straight. Integrated ON/OFF Nylon brake pedals for easy and quiet operation. Release pedal in green color.

R Round Stem

ARB Wheel Al-alloy hub, grey color high elastic rubber tire

Brake type	mm	mm		mm	mm	mm	mm	mm	mm	mm	kg	Code
TB Total locking brake	125	32		22.0	45.0	19.0	M8x1.25	39.0	161.0	100		DC125BR8/W529U
	125	32		28.0	45.0	19.0	M8x1.25	39.0	161.0	100		DC125BR9/W529U
	125	32		25.6	45.0	19.0	M8x1.25	39.0	161.0	100		DC125BR16/W529U
DB Dir. locking brake	125	32		22.0	45.0	19.0	M8x1.25	39.0	161.0	100		DC125DBR8/W529U
	125	32		28.0	45.0	19.0	M8x1.25	39.0	161.0	100		DC125DBR9/W529U
	125	32		25.6	45.0	19.0	M8x1.25	39.0	161.0	100		DC125DBR16/W529U
Non-brake Free swivel	125	32		22.0	45.0	19.0	M8x1.25	39.0	161.0	100		DC125R8/W529U
	125	32		28.0	45.0	19.0	M8x1.25	39.0	161.0	100		DC125R9/W529U
	125	32		25.6	45.0	19.0	M8x1.25	39.0	161.0	100		DC125R16/W529U



T Threaded Stem Fitting with Hex Base Washer



TPR Wheel

Plastic hub, grey color thermoplastic rubber tire

Brake type	mm	mm		mm	mm	mm	mm	kg	Code
TB/A Total locking brake	100	25		1/2-13UNC	1"	38.5	135.0	60	DC100BT2/W412
	100	25		M12 P1.75	25.0	38.5	135.0	60	DC100BT4/W412
	100	25		M16 P2.0	25.0	38.5	135.0	60	DC100BT5/W412
	100	25		1/2-20UNF	25.0	38.5	135.0	60	DC100BT10/W412
	125	32		1/2-13UNC	1"	39.0	161.0	100	DC125BT2/W502
	125	32		M12 P1.75	25.0	39.0	161.0	100	DC125BT4/W502
	125	32		M16 P2.0	25.0	39.0	161.0	100	DC125BT5/W502
	125	32		1/2-20UNF	25.0	39.0	161.0	100	DC125BT10/W502
	125	32		1/2-13UNC	1"	39.0	161.0	100	DC125BT2/W502U
	125	32		M12 P1.75	25.0	39.0	161.0	100	DC125BT4/W502U
	125	32		M16 P2.0	25.0	39.0	161.0	100	DC125BT5/W502U
	125	32		1/2-20UNF	25.0	39.0	161.0	100	DC125BT10/W502U
Non-brake Free swivel	125	32		1/2-13UNC	1"	39.0	161.0	100	DC125T2/W502
	125	32		M12 P1.75	25.0	39.0	161.0	100	DC125T4/W502
	125	32		M16 P2.0	25.0	39.0	161.0	100	DC125T5/W502
	125	32		1/2-20UNF	25.0	39.0	161.0	100	DC125T10/W502
	125	32		1/2-13UNC	1"	39.0	161.0	100	DC125T2/W502U
	125	32		M12 P1.75	25.0	39.0	161.0	100	DC125T4/W502U
	125	32		M16 P2.0	25.0	39.0	161.0	100	DC125T5/W502U
	125	32		1/2-20UNF	25.0	39.0	161.0	100	DC125T10/W502U



Pressed steel, zinc-chromatized double ballrace swivel yoke, aesthetic streamlined ABS covers



TB/A Total locking brake
Total Lock system locks both swivel head and wheel simultaneously for secure parking. Integrated ON/OFF Nylon brake pedals for easy and quiet operation.



DB/A Directional locking brake
Directional Lock permits free wheel rotation while swivel head remains locked, an easy way to keep equipment traveling straight. Integrated ON/OFF Nylon brake pedals for easy and quiet operation. Release pedal in green color.

T Threaded Stem Fitting with Hex Base Washer

















TPU Wheel Plastic hub, grey color polyurethane tire

Brake type	mm	mm		mm	mm	mm	mm	kg	Code
TB/A Total locking brake	125	32		1/2-13UNC	1"	39.0	161.0	100	DC125BT2/W501
	125	32		M12 P1.75	25.0	39.0	161.0	100	DC125BT4/W501
	125	32		M16 P2.0	25.0	39.0	161.0	100	DC125BT5/W501
	125	32		1/2-20UNF	25.0	39.0	161.0	100	DC125BT10/W501
	125	32		1/2-13UNC	1"	39.0	161.0	100	DC125BT2/W501U
	125	32		M12 P1.75	25.0	39.0	161.0	100	DC125BT4/W501U
	125	32		M16 P2.0	25.0	39.0	161.0	100	DC125BT5/W501U
	125	32		1/2-20UNF	25.0	39.0	161.0	100	DC125BT10/W501U
Non-brake Free swivel	125	32		1/2-13UNC	1"	39.0	161.0	100	DC125T2/W501
	125	32		M12 P1.75	25.0	39.0	161.0	100	DC125T4/W501
	125	32		M16 P2.0	25.0	39.0	161.0	100	DC125T5/W501
	125	32		1/2-20UNF	25.0	39.0	161.0	100	DC125T10/W501
	125	32		1/2-13UNC	1"	39.0	161.0	100	DC125T2/W501U
	125	32		M12 P1.75	25.0	39.0	161.0	100	DC125T4/W501U
	125	32		M16 P2.0	25.0	39.0	161.0	100	DC125T5/W501U
	125	32		1/2-20UNF	25.0	39.0	161.0	100	DC125T10/W501U



T Threaded Stem Fitting with Hex Base Washer

ARB Wheel Al-alloy hub, grey color high elastic rubber tire

Brake type	 mm	 mm		 mm	 mm	 mm	 mm	 kg	Code
TB/A Total locking brake	125	32		1/2-13UNC	1"	39.0	161.0	100	DC125BT2/W529U
	125	32		M12 P1.75	25.0	39.0	161.0	100	DC125BT4/W529U
	125	32		M16 P2.0	25.0	39.0	161.0	100	DC125BT5/W529U
	125	32		1/2-20UNF	25.0	39.0	161.0	100	DC125BT10/W529U
Non-brake Free swivel	125	32		1/2-13UNC	1"	39.0	161.0	100	DC125T2/W529U
	125	32		M12 P1.75	25.0	39.0	161.0	100	DC125T4/W529U
	125	32		M16 P2.0	25.0	39.0	161.0	100	DC125T5/W529U
	125	32		1/2-20UNF	25.0	39.0	161.0	100	DC125T10/W529U



BB-TEK

Bi-brake Castors

Our patented BB-Tek is a star creation of Catis and a pride of Taiwan.

Incorporated into the same castor are two locking functions unseen in the trade, that is Total Locking and Directional Locking combined in one unit. Its simplicity in use and reliability is unmatched by any castor made, and has been most favored by medical appliances manufacturers and high-tech industry in the world.

With a slight touch of pedal, you can lock the swivel head and moves straight ahead. Likewise, you can choose to unlock the wheel for lateral movement, or another tap to have the equipment firmly parked.

All carried out at the tip of the toe.

Application:
Medical diagnostic machines;
hi-tech apparatus.

Size Available:
125x32, 150x40, 200x40mm

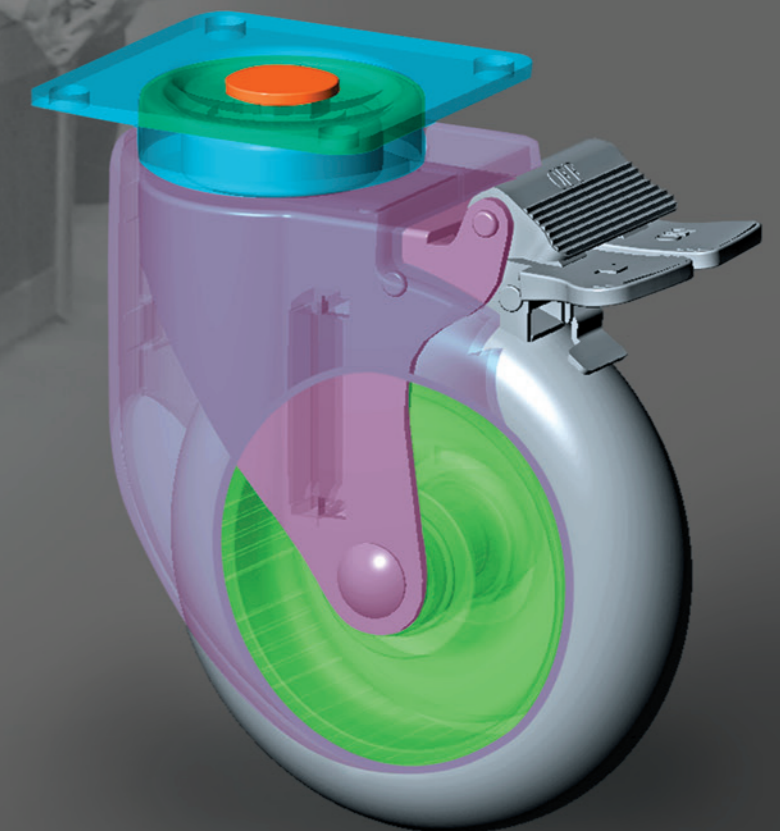

Pressed steel, zinc-chromatized swivel yoke, precision ball bearing at axle, aesthetic ABS covers; for 125mm wheel, double ballrace swivel head; for 150mm and 200mm wheels, precision ball bearing at swivel head; patented bi-brake design provides total locking and directional locking in one system



BB/ Two In One Bi-Brake System

Two locking functions, Directional and Total Lock incorporated into a single castor. When straight-line tracking is required, simply engage the Directional Lock (green pedal); switching to safe parking is equally easy with a single tap of the Total Lock (red pedal). Unleash all locks for lateral movement and easy maneuvering in tight space and turning corners.

P Top Plate Fitting



TPR Wheel Plastic hub, grey color thermoplastic rubber tire

Brake type	mm	mm		mm	mm	mm	mm	mm	kg	Code
BB/ Bi-Brake	125	32		95 x 70	75 x 52 / 72 x 45	9.0	39.0	161.0	100	TS125BP1/W502U
	125	32		77 x 67	61.5 x 52 / 56 x 45	8.5	39.0	161.0	100	TS125BP2/W502U
	150	40		114.3 x 101.6	93 x 67	9.0	46.0	196.5	150	TS150BP6/W630U
	150	40		100 x 100	80 x 80	10.0	46.0	196.5	150	TS150BP8/W630U



ARB Wheel Al-alloy hub, grey color high elastic rubber tire

Brake type	mm	mm		mm	mm	mm	mm	mm	kg	Code
BB/ Bi-Brake	125	32		95 x 70	75 x 52 / 72 x 45	9.0	39.0	161.0	100	TS125BP1/W529U
	125	32		77 x 67	61.5 x 52 / 56 x 45	8.5	39.0	161.0	100	TS125BP2/W529U
	150	40		114.3 x 101.6	93 x 67	9.0	46.0	196.5	150	TS150BP6/W640U
	150	40		100 x 100	80 x 80	10.0	46.0	196.5	150	TS150BP8/W640U
	200	40		114.3 x 101.6	93 x 67	9.0	49.0	250.0	150	TS200BP6/W840U
	200	40		100 x 100	80 x 80	10.0	49.0	250.0	150	TS200BP8/W840U



Brake type	mm	mm		mm	mm	mm	mm	kg	Code
Non-brake Fixed	200	40		114.3 x 101.6	93 x 67	9.0	250.0	150	TS203P6/W840U



P Top Plate Fitting

TPU Wheel Plastic hub, grey color polyurethane tire

Brake type										kg	Code
	125	32		95 x 70	75 x 52 / 72 x 45	9.0	39.0	161.0	100		TS125BP1/W501U
Bi-Brake	125	32		77 x 67	61.5 x 52 / 56 x 45	8.5	39.0	161.0	100		TS125BP2/W501U

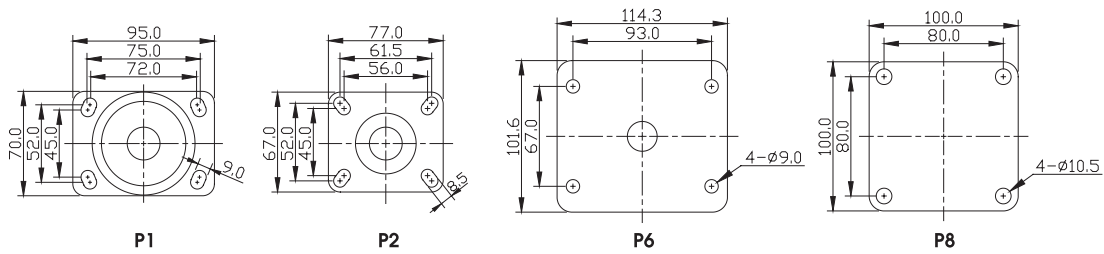

Pressed steel, zinc-chromatized swivel yoke, precision ball bearing at axle, aesthetic ABS covers; for 125mm wheel, double ballrace swivel head; for 150mm and 200mm wheels, precision ball bearing at swivel head; patented bi-brake design provides total locking and directional locking in one system



BB Two In One Bi-Brake System

Two locking functions, Directional and Total Lock incorporated into a single castor. When straight-line tracking is required, simply engage the Directional Lock (green pedal); switching to safe parking is equally easy with a single tap of the Total Lock (red pedal). Unleash all locks for lateral movement and easy maneuvering in tight space and turning corners.

R Round Stem



TPR Wheel Plastic hub, grey color thermoplastic rubber tire

Brake type	mm	mm								kg	Code
BB Bi-Brake	125	32								100	TS125BR8/W502U
	125	32								100	TS125BR9/W502U
	125	32								100	TS125BR16/W502U
	150	40								150	TS150BR8/W630U
	150	40								150	TS150BR9/W630U
	150	40								150	TS150BR16/W630U



ARB Wheel Al-alloy hub, grey color high elastic hubber tire





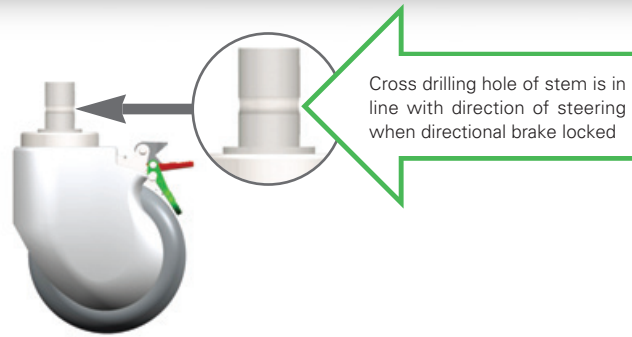









Brake type	mm	mm								kg	Code
BB Bi-Brake	125	32								100	TS125BR8/W529U
	125	32								100	TS125BR9/W529U
	125	32								100	TS125BR16/W529U
	150	40								150	TS150BR8/W640U
	150	40								150	TS150BR9/W640U
	150	40								150	TS150BR16/W640U
	200	40								150	TS200BR8/W840U
	200	40								150	TS200BR9/W840U
	200	40								150	TS200BR16/W840U





R Round Stem

TPU Wheel Plastic hub, grey color polyurethane tire

Brake type	 mm	 mm		 mm	 mm	 mm	 mm	 mm	 mm	 kg	Code
 Bi-Brake	125	32		22.0	45.0	19.0	M8x1.25	39.0	161.0	100	TS125BR8/W501U
	125	32		28.0	45.0	19.0	M8x1.25	39.0	161.0	100	TS125BR9/W501U
	125	32		25.6	45.0	19.0	M8x1.25	39.0	161.0	100	TS125BR16/W501U



FUTURA

Suspension Castors

U.S. Patent US 6,823,560 B2

Our Futura adds another dimension to the meaning of Performance Art. Its patented suspension and braking design is a total revolution in castor industry.

Secluded behind the dynamic casing, is the heart and soul of this innovation: locking and suspension components, all protected within a single piece of steel housing. Braking is acted on the internal surface of the wheel leaving no dent on the tread and markedly reduces the chance for tire damage. All intended to provide your valuable and sensitive equipment with the protection and convenience it needs.

Since the advent of the Futura, major manufacturers in medical diagnostic equipments dare to restructure and upgrade their products, realizing that Futura could move their prized equipments around, without the nagging concern of system breakdown due to vibrations during motion. If your products deserve a TLC mover, this is it!

At Catis, we always look for better solutions.

Applications:

High-end medical diagnostic ultrasound machines; sensitive electronic equipments.

Size available:

150 mm

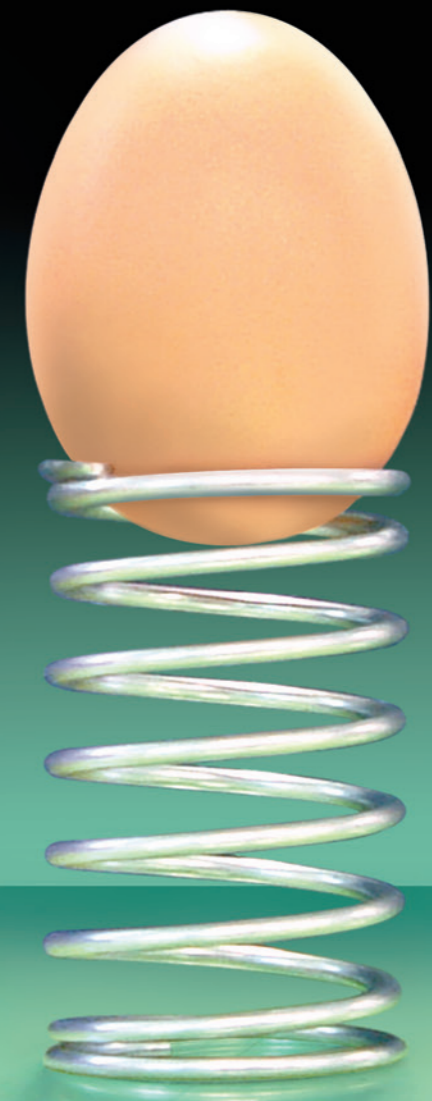
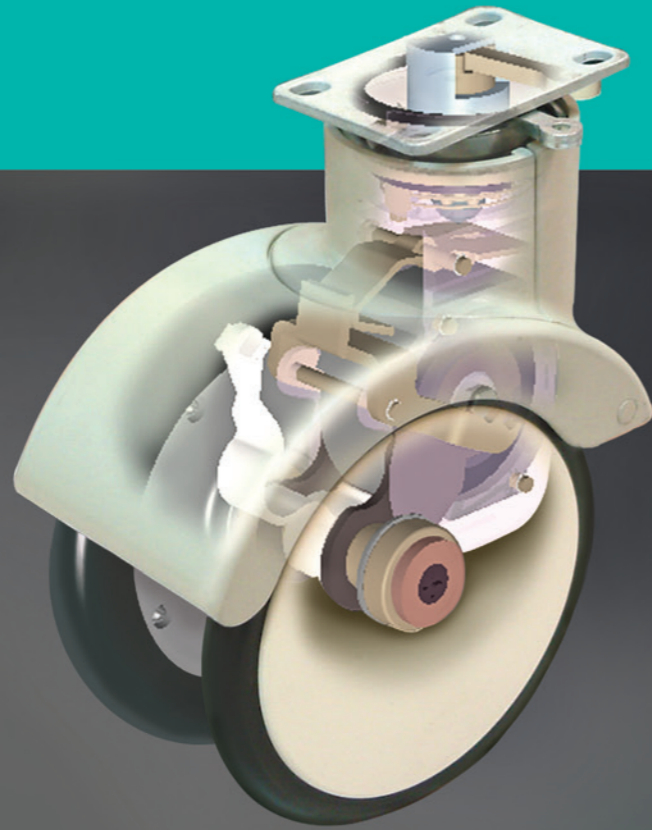





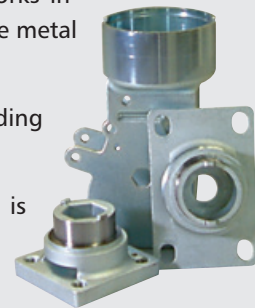

FEATURES

- ABS mud guard, designed to rise and fall with wheel motion, allowing maximum clearance at mounting interface. It is easy to maintain, preventing cable and wire caught in between wheels, and keeps wheels from collecting food spill and dirt. Would not decolorize because color pigment is included in injection process.
- Innovated dual brake design that operates from the inside of the wheel. As braking acts on the internal surface of the wheel, it eliminates abrasion on tread surface, which often leads to wheel damage.

- Precision ball bearings at swivel head and wheel axle warrant quiet transport, and minimize starting and swivel resistance.
- Rubber formulated separately for the twin wheels and patented suspension core works in synergy to provide easy maneuvering, and maximum shock dampening function. Unlike metal spring, rebound is smooth and quiet.
- Exceptional structural strength as yoke, and top plate are mold cast, without any welding weak spot. Zinc plating finish provides long lasting protection.
- Each castor is designed to carry 100kgs (220lbs), but a total load of 300kgs (660lbs) is recommended for the vehicles using 4 castors, as frequently, only 3 castors are in contact with ground surface.



OPTIONS

4 standard colors: Grey  Ivory  Green  and Blue 













4 standard operating modes: Free swivel; (round stem fitting is available to this mode only)

Directional lock / Free swivel









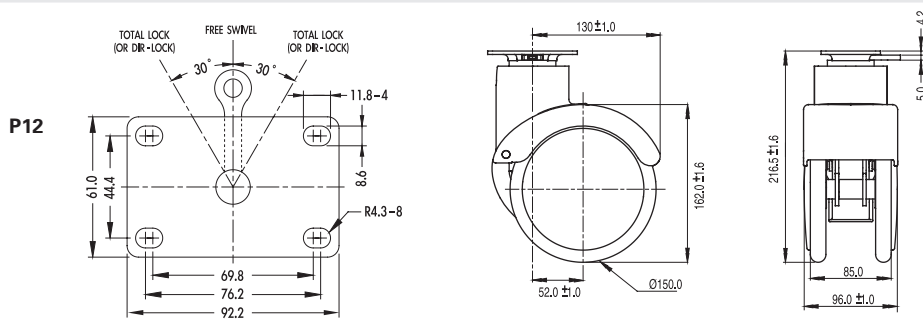

Total lock / Free swivel

Total lock / Free swivel / Directional lock

Color, covers and mounting configuration can be customized to match your equipment (see Custom Made P189).

Brake type	 mm	 mm			 mm	 mm	 mm	 kg		Code	
Total lock	150	16x2		Rubber	P12	52	130	216.5	100	70±5 A	SU150BP12/RB
Dir. lock	150	16x2		Rubber	P12	52	130	216.5	100	70±5 A	SU150DBP12/RB
Non-brake Free swivel	150	16x2		Rubber	P12	52	130	216.5	100	70±5 A	SU150P12/RB



Brake type	 mm	 mm			 mm	 mm	 mm	 kg		Code	
Free swivel Total lock Dir. lock	150	16x2		Rubber	P13	52	130	226.1	100	70±5 A	SU150BBP13/RB
Non-brake Free swivel	150	16x2		Rubber	P13	52	130	226.1	100	70±5 A	SU150P13/RB

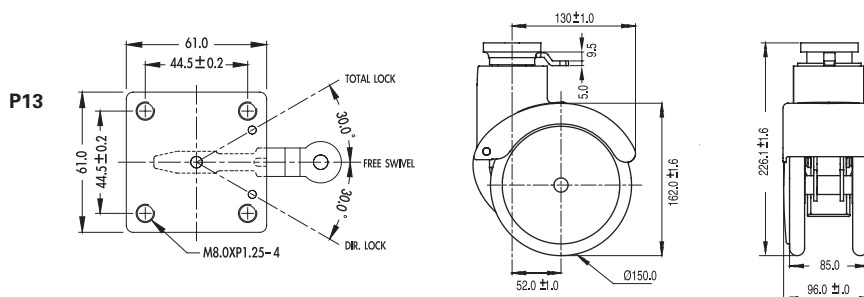

TW

Twin Wheel Castors

The twin wheel design provides wider traction surface and stability for the mobile units. While it is widely used with catering trolleys in order to reduce annoying food spillage, hoist and lifts used for patients transfer in health care business found it equally indispensable.

Application:
Catering trolleys; patients transfer carts.

Size Available:
75x25mmx2, 100x25mmx2

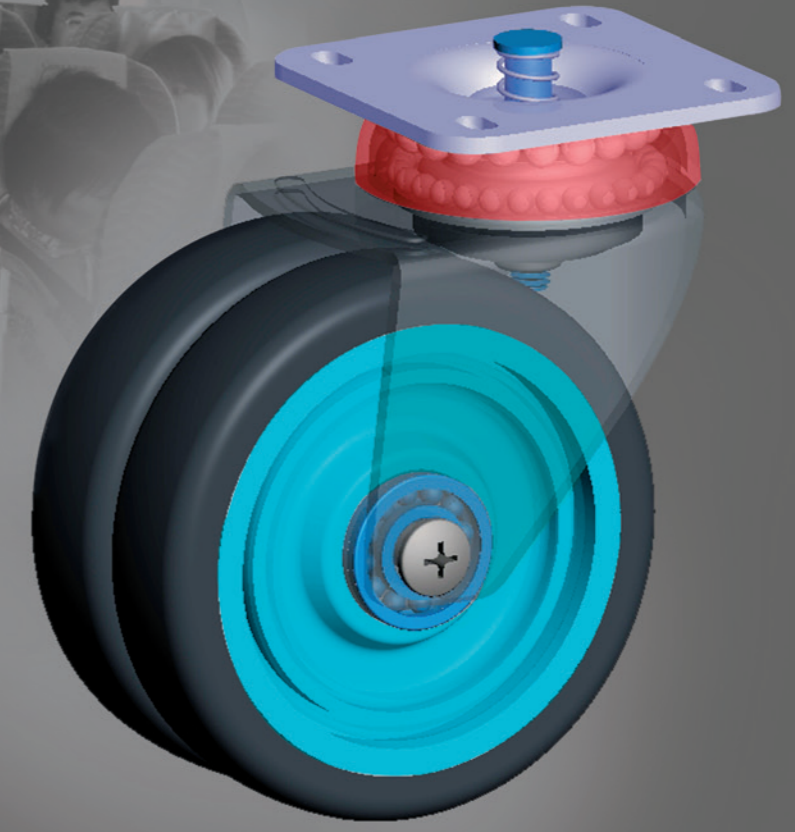

Pressed steel, zinc-chromatized double ball race swivel yoke, twin wheels design

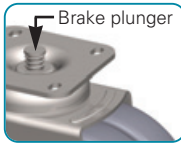

TWB Wheel locking brake

Widely used for mobile units equipped with a centralized lock linkage system. Wheel braking / release is activated by means of a brake plunger which is in turn controlled by the linkage system.

P Top Plate Fitting

TPR Wheel Plastic hub, grey color thermoplastic rubber tire

Brake type	mm	mm	mm	mm	mm	mm	mm	mm	kg	Code
Wheel locking brake	075x2	25x2		70 x 55	56.5 x 41 / 50.5 x 41	5.5	31.4	103.0	100	TW75BP4/W312N
	100x2	25x2		70 x 55	56.5 x 41 / 50.5 x 41	5.5	37.0	126.5	100	TW100BP4/W412N
Non-brake Free swivel	075x2	25x2		77 x 67	61.5 x 52 / 56.0 x 45	8.5	31.4	103.0	100	TW75P2/W312N
	075x2	25x2		70 x 55	56.5 x 41 / 50.5 x 41	5.5	31.4	103.0	100	TW75P4/W312N
	100x2	25x2		77 x 67	61.5 x 52 / 56.0 x 45	8.5	37.0	126.5	100	TW100P2/W412N
	100x2	25x2		70 x 55	56.5 x 41 / 50.5 x 41	5.5	37.0	126.5	100	TW100P4/W412N



TPU Wheel Plastic hub, grey color polyurethane tire

Brake type	mm	mm	mm	mm	mm	mm	mm	mm	kg	Code
Wheel locking brake	075x2	25x2		70 x 55	56.5 x 41 / 50.5 x 41	5.5	31.4	103.0	100	TW75BP4/W315CX
	100x2	25x2		70 x 55	56.5 x 41 / 50.5 x 41	5.5	37.0	126.5	100	TW100BP4/W415CX
Non-brake Free swivel	075x2	25x2		77 x 67	61.5 x 52 / 56.0 x 45	8.5	31.4	103.0	100	TW75P2/W315CX
	075x2	25x2		70 x 55	56.5 x 41 / 50.5 x 41	5.5	31.4	103.0	100	TW75P4/W315CX
	100x2	25x2		77 x 67	61.5 x 52 / 56.0 x 45	8.5	37.0	126.5	100	TW100P2/W415CX
	100x2	25x2		70 x 55	56.5 x 41 / 50.5 x 41	5.5	37.0	126.5	100	TW100P4/W415CX

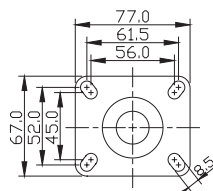



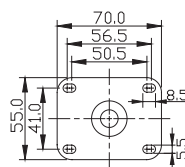









P2



P4













T Threaded Stem Fitting with Hex Base Washer

TPR Wheel Plastic hub, grey color thermoplastic rubber tire

Brake type	 mm	 mm		 mm	 mm	 mm	 mm	 kg	Code
Non-brake Free swivel	075x2	25x2		1/2-13UNC	1"	31.4	103.0	100	TW75T2/W312N
	075x2	25x2		M12 P1.75	25.0	31.4	103.0	100	TW75T4/W312N
	100x2	25x2		1/2-13UNC	1"	37.0	126.5	100	TW100T2/W412N
	100x2	25x2		M12 P1.75	25.0	37.0	126.5	100	TW100T4/W412N



TPU Wheel Plastic hub, grey color polyurethane tire

Brake type	 mm	 mm		 mm	 mm	 mm	 mm	 kg	Code
Non-brake Free swivel	075x2	25x2		1/2-13UNC	1"	31.4	103.0	100	TW75T2/W315CX
	075x2	25x2		M12 P1.75	25.0	31.4	103.0	100	TW75T4/W315CX
	100x2	25x2		1/2-13UNC	1"	37.0	126.5	100	TW100T2/W415CX
	100x2	25x2		M12 P1.75	25.0	37.0	126.5	100	TW100T4/W415CX



TW

Twin Wheel Castors

Pressed steel, zinc-chromatized double ball race swivel yoke, twin wheels design

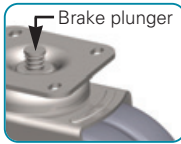













TWB Wheel locking brake

Widely used for mobile units equipped with a centralized lock linkage system. Wheel braking / release is activated by means of a brake plunger which is in turn controlled by the linkage system.

H Bolt Hole Fitting

TPR Wheel Plastic hub, grey color thermoplastic rubber tire

Brake type	 mm	 mm		 mm	 mm	 mm	 kg	Code
Non-brake Free swivel	075x2	25x2		10.3	31.4	100.0	100	TW75H1/W312N
	075x2	25x2		12.3	31.4	100.0	100	TW75H2/W312N
	075x2	25x2		12.8	31.4	100.0	100	TW75H3/W312N
	100x2	25x2		10.3	37.0	123.5	100	TW100H1/W412N
	100x2	25x2		12.3	37.0	123.5	100	TW100H2/W412N
	100x2	25x2		12.8	37.0	123.5	100	TW100H3/W412N



TPU Wheel Plastic hub, grey color polyurethane tire

Brake type	 mm	 mm		 mm	 mm	 mm	 kg	Code
Non-brake Free swivel	075x2	25x2		10.3	31.4	100.0	100	TW75H1/W315CX
	075x2	25x2		12.3	31.4	100.0	100	TW75H2/W315CX
	075x2	25x2		12.8	31.4	100.0	100	TW75H3/W315CX
	100x2	25x2		10.3	37.0	123.5	100	TW100H1/W415CX
	100x2	25x2		12.3	37.0	123.5	100	TW100H2/W415CX
	100x2	25x2		12.8	37.0	123.5	100	TW100H3/W415CX



Option: Stainless Steel Twin Wheels Castors

Pressed stainless steel double ballrace swivel yoke, electrolytic polishing finish, thermoplastic rubber wheel with stainless steel precision ball bearing (AISI440C) and threadguards, all metal parts in stainless steel material

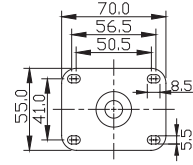

P4

P Top Plate Fitting

TPR-SS Wheel Plastic hub, grey color thermoplastic rubber tire

Brake type	mm	mm		mm	mm	mm	mm	mm	kg	Code
TWB	075x2	25x2		70 x 55	56.5 x 41 / 50.5 x 41	5.5	31.4	103.0	100	TW75BP4SS/W312NS
Wheel locking brake	100x2	25x2		70 x 55	56.5 x 41 / 50.5 x 41	5.5	37.0	126.5	100	TW100BP4SS/W412NS
Non-brake	075x2	25x2		70 x 55	56.5 x 41 / 50.5 x 41	5.5	31.4	103.0	100	TW75P4SS/W312NS
Free swivel	100x2	25x2		70 x 55	56.5 x 41 / 50.5 x 41	5.5	37.0	126.5	100	TW100P4SS/W412NS



T Threaded Stem Fitting with Hex Base Washer

TPR-SS Wheel Plastic hub, grey color thermoplastic rubber tire

Brake type	mm	mm		mm	mm	mm	mm	mm	kg	Code
Non-brake	075x2	25x2		1/2-13UNC	1"	31.4	103.0	100	100	TW75T2SS/W312NS
Free swivel	075x2	25x2		M12 P1.75	25.0	31.4	103.0	100	100	TW75T4SS/W312NS
	100x2	25x2		1/2-13UNC	1"	37.0	126.5	100	100	TW100T2SS/W412NS
	100x2	25x2		M12 P1.75	25.0	37.0	126.5	100	100	TW100T4SS/W412NS



H Bolt Hole Fitting

TPR-SS Wheel Plastic hub, grey color thermoplastic rubber tire

Brake type	mm	mm		mm	mm	mm	mm	kg	Code	
Non-brake	075x2	25x2		10.3	31.4	100.0	100	100	100	TW75H1SS/W312NS
Free swivel	075x2	25x2		12.3	31.4	100.0	100	100	100	TW75H2SS/W312NS
	075x2	25x2		12.8	31.4	100.0	100	100	100	TW75H3SS/W312NS
	100x2	25x2		10.3	37.0	123.5	100	100	100	TW100H1SS/W412NS
	100x2	25x2		12.3	37.0	123.5	100	100	100	TW100H2SS/W412NS
	100x2	25x2		12.8	37.0	123.5	100	100	100	TW100H3SS/W412NS



A highly stylized engineering plastic castor whose sturdiness comes from fiberglass reinforced plastic body. Firm and easy steering is a result of precision ball bearing being embedded into the swivel head during injection process, a procedure that secure the bearing and adding extra strength to the yoke at the same time. Total water proofing can be achieved by using stainless steel metal components and washable lubricant.

While stainless steel castor is the best choice to use around moisture prone areas, it is often less desirable for its obtrusive metallic effect, especially used with health care equipments. When conditions demand for a human touch and subtleness, our plastic PT castor would be the best choice without debate.

PT

Polytech Castors

Application:

Rehabilitating trolleys/carts; medical cabinets; food carts; infant carriages; business machines.

Size Available:

100x25, 125x32mm



Nylon 6 with fiber-glass reinforced body, precision ball bearing swivel head, thermoplastic rubber wheel with ball bearings



TB/c Total locking brake
Total Lock system locks both swivel head and wheel simultaneously for a secure parking. Grey color Nylon brake pedal.
Available for PolyTech series only.



DB/c Directional locking brake
Directional Lock permits free wheel rotation while swivel head remains locked, an easy way to keep equipment traveling straight. Green color Nylon brake pedal.
Available for PolyTech series only.

P Top Plate Fitting

TPR Wheel Plastic hub, grey color thermoplastic rubber tire



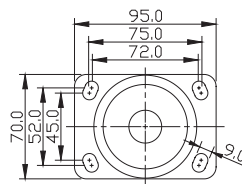



















Brake type	mm	mm		mm	mm	mm	mm	mm	kg	Code
TB/c Total locking brake	100	25		95 x 70	75 x 52 / 72 x 45	9.0	35.0	142.0	60	PT100BP1/W402
	125	32		95 x 70	75 x 52 / 72 x 45	9.0	44.0	166.0	100	PT125BP1/W502
DB/c Dir. locking brake	125	32		95 x 70	75 x 52 / 72 x 45	9.0	44.0	166.0	100	PT125DBP1/W502
Non-brake Free swivel	100	25		95 x 70	75 x 52 / 72 x 45	9.0	35.0	142.0	60	PT100P1/W402
	125	32		95 x 70	75 x 52 / 72 x 45	9.0	44.0	166.0	100	PT125P1/W502



P1

R Round Stem

TPR Wheel Plastic hub, grey color thermoplastic rubber tire

Brake type	 mm	 mm		 mm	 mm	 mm	 mm	 mm	 mm	 kg	Code	
TB/c Total locking brake	125	32		22.0	45.0	19.0	M8x1.25	44.0	166.0	100	PT125BR8/W502	
	125	32		28.0	45.0	19.0	M8x1.25	44.0	166.0	100	PT125BR9/W502	
	125	32		25.6	45.0	19.0	M8x1.25	44.0	166.0	100	PT125BR16/W502	
DB/c Dir. locking brake	125	32		22.0	45.0	19.0	M8x1.25	44.0	166.0	100	PT125DBR8/W502	
	125	32		28.0	45.0	19.0	M8x1.25	44.0	166.0	100	PT125DBR9/W502	
	125	32		25.6	45.0	19.0	M8x1.25	44.0	166.0	100	PT125DBR16/W502	
Non-brake Free swivel	125	32		22.0	45.0	19.0	M8x1.25	44.0	166.0	100	PT125R8/W502	
	125	32		28.0	45.0	19.0	M8x1.25	44.0	166.0	100	PT125R9/W502	
	125	32		25.6	45.0	19.0	M8x1.25	44.0	166.0	100	PT125R16/W502	

Nylon 6 with fiber-glass reinforced body, precision ball bearing swivel head, thermoplastic rubber wheel with ball bearings



TB/c Total locking brake
Total Lock system locks both swivel head and wheel simultaneously for a secure parking. Grey color Nylon brake pedal.
Available for PolyTech series only.



DB/c Directional locking brake
Directional Lock permits free wheel rotation while swivel head remains locked, an easy way to keep equipment traveling straight. Green color Nylon brake pedal.
Available for PolyTech series only.

T Threaded Stem Fitting

TPR Wheel Plastic hub, grey color thermoplastic rubber tire



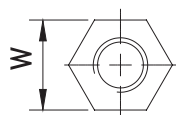











Brake type	mm	mm	mm	mm	mm	mm	mm	kg	Code
TB/c Total locking brake	100	25		1/2-13UNC	30.0	35.0	139.0	60	PT100BT2+/W402
	100	25		M10 P1.5	28.0	35.0	139.0	60	PT100BT3+/W402
	100	25		M12 P1.75	28.0	35.0	139.0	60	PT100BT4+/W402
	100	25		M16 P2.0	25.0	35.0	139.0	60	PT100BT5/W402
	100	25		1/2-20UNF	28.0	35.0	139.0	60	PT100BT10+/W402
	125	32		1/2-13UNC	30.0	44.0	166.0	100	PT125BT2+/W502
	125	32		M10 P1.5	28.0	44.0	166.0	100	PT125BT3+/W502
	125	32		M12 P1.75	28.0	44.0	166.0	100	PT125BT4+/W502
	125	32		M16 P2.0	25.0	44.0	166.0	100	PT125BT5/W502
	125	32		1/2-20UNF	28.0	44.0	166.0	100	PT125BT10+/W502
Non-brake Free swivel	100	25		1/2-13UNC	30.0	35.0	139.0	60	PT100T2+/W402
	100	25		M10 P1.5	28.0	35.0	139.0	60	PT100T3+/W402
	100	25		M12 P1.75	28.0	35.0	139.0	60	PT100T4+/W402
	100	25		M16 P2.0	25.0	35.0	139.0	60	PT100T5/W402
	100	25		1/2-20UNF	28.0	35.0	139.0	60	PT100T10+/W402
	125	32		1/2-13UNC	30.0	44.0	166.0	100	PT125T2+/W502
	125	32		M10 P1.5	28.0	44.0	166.0	100	PT125T3+/W502
	125	32		M12 P1.75	28.0	44.0	166.0	100	PT125T4+/W502
	125	32		M16 P2.0	25.0	44.0	166.0	100	PT125T5/W502
	125	32		1/2-20UNF	28.0	44.0	166.0	100	PT125T10+/W502



Code	W
T2+	19
T3+	17
T4+	19
T5	24
T10+	19

F Friction Ring Stem

TPR Wheel Plastic hub, grey color thermoplastic rubber tire

Brake type	 mm	 mm		 mm	 mm	 mm	 mm	 mm	 mm	 mm	 kg	Code
 Total locking brake	125	32		21.5	23.0	55.0	45.2	2.4	44.0	166.0	100	PT125BF3/W502
Non-brake Free swivel	125	32		21.5	23.0	55.0	45.2	2.4	44.0	166.0	100	PT125F3/W502



Option: Stainless Steel PolyTech Castors

For total water-proofing and corrosion resistant, all metal parts in stainless steel material



TB/c Total locking brake

Total Lock system locks both swivel head and wheel simultaneously for a secure parking. Grey color Nylon brake pedal. Available for PolyTech series only.



DB/c Directional locking brake

Directional Lock permits free wheel rotation while swivel head remains locked, an easy way to keep equipment traveling straight. Green color Nylon brake pedal. Available for PolyTech series only.

P Top Plate Fitting



TPR-SS Wheel

Plastic hub, grey color thermoplastic rubber tire



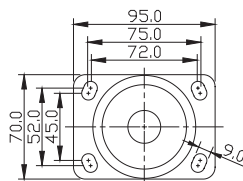















Brake type	mm	mm		mm	mm	mm	mm	mm	mm	kg	Code
TB/c Total locking brake	100	25		95 x 70	75 x 52 / 72 x 45	9.0	35.0	142.0	60		PT100BP1SS/W402S
	125	32		95 x 70	75 x 52 / 72 x 45	9.0	44.0	166.0	100		PT125BP1SS/W502S
DB/c Dir. locking brake	125	32		95 x 70	75 x 52 / 72 x 45	9.0	44.0	166.0	100		PT125DBP1SS/W502S
	Non-brake Free swivel	100	25		95 x 70	75 x 52 / 72 x 45	9.0	35.0	142.0	60	
125		32		95 x 70	75 x 52 / 72 x 45	9.0	44.0	166.0	100		PT125P1SS/W502S



P1

T Threaded Stem Fitting

TPR-SS Wheel Plastic hub, grey color thermoplastic rubber tire

Brake type	mm	mm		mm	mm	mm	mm	kg	Code
 Total locking brake	100	25		1/2-13UNC	30.0	35.0	139.0	60	PT100BT2+SS/W402S
	100	25		M10 P1.5	28.0	35.0	139.0	60	PT100BT3+SS/W402S
	100	25		M12 P1.75	28.0	35.0	139.0	60	PT100BT4+SS/W402S
	100	25		M16 P2.0	25.0	35.0	139.0	60	PT100BT5SS/W402S
	125	32		1/2-13UNC	30.0	44.0	166.0	100	PT125BT2+SS/W502S
	125	32		M10 P1.5	28.0	44.0	166.0	100	PT125BT3+SS/W502S
	125	32		M12 P1.75	28.0	44.0	166.0	100	PT125BT4+SS/W502S
	125	32		M16 P2.0	25.0	44.0	166.0	100	PT125BT5SS/W502S
Non-brake Free swivel	100	25		1/2-13UNC	30.0	35.0	139.0	60	PT100T2+SS/W402S
	100	25		M10 P1.5	28.0	35.0	139.0	60	PT100T3+SS/W402S
	100	25		M12 P1.75	28.0	35.0	139.0	60	PT100T4+SS/W402S
	100	25		M16 P2.0	25.0	35.0	139.0	60	PT100T5SS/W402S
	125	32		1/2-13UNC	30.0	44.0	166.0	100	PT125T2+SS/W502S
	125	32		M10 P1.5	28.0	44.0	166.0	100	PT125T3+SS/W502S
	125	32		M12 P1.75	28.0	44.0	166.0	100	PT125T4+SS/W502S
	125	32		M16 P2.0	25.0	44.0	166.0	100	PT125T5SS/W502S



 Stainless steel

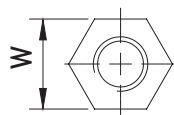

Code	W
T2+	19
T3+	17
T4+	19
T5	24
T10+	19



An excellent partner for your mobile retail equipments.

A silent companion for your customers, giving them a smooth shopping trip and a peace of mind

Single disc travelator castor has provided shoppers decades of safety trip on and off the autowalks, and still, it is the most popular castor used throughout the retail outlets in the world.

Application:

Mobile retail equipments;
shopping trolleys;
airport baggage trolleys.

Size Available:



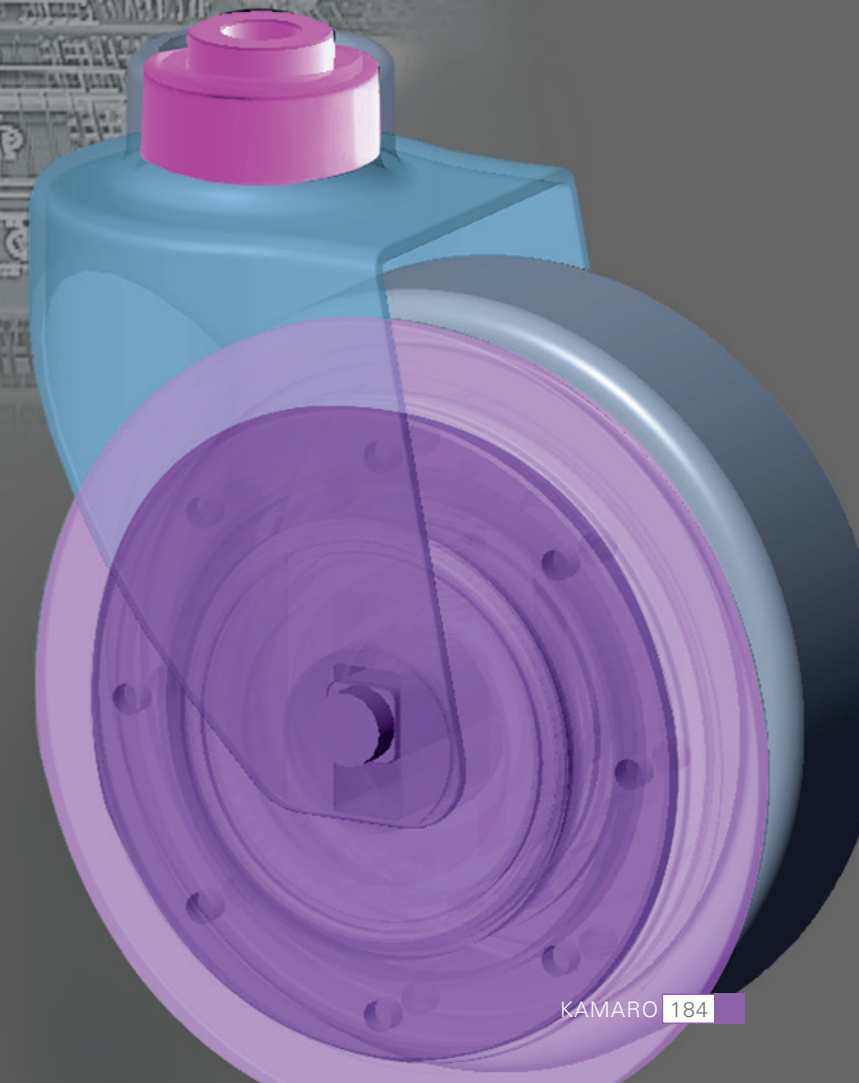











50x22, 60x25, 75x25, 100x32,
125x32mm

















Pressed steel, zinc-chromatized double ballrace swivel yoke, designed mainly for shopping trolley and other mobile retail equipments; single disc walkway castor only available in 125mm size

H Bolt Hole Fitting

TPR Wheel Plastic hub, grey color thermoplastic rubber tire

Brake type	 mm	 mm		 mm	 mm	 mm	 kg	Code	
Non-brake Free swivel	75	25		10.3	30.0	103.0	50	Y329H1/W303CX	
	100	32		12.3	35.0	130.5	80	Y429H2/W403	
	125	32		12.3	38.0	154.5	100	Y529H2/W503	
	125	32		12.3	38.0	154.5	100	Y529H2/W503U	
	125	32		12.3	41.5	158.5	100	Y533H2/W503	

TPU Wheel Plastic hub, grey color polyurethane tire

Brake type	 mm	 mm		 mm	 mm	 mm	 kg	Code	
Non-brake Free swivel	50	22		8.3	21.0	66.0	30	Y285H0/W285	
	60	25		10.3	27.0	81.5	40	Y286H1/W286P	
	75	25		12.3	30.0	103.0	50	Y329H2/W305CX	
	100	32		12.3	35.0	130.5	80	Y429H2/W400	
	125	32		12.3	38.0	154.5	100	Y529H2/W500	

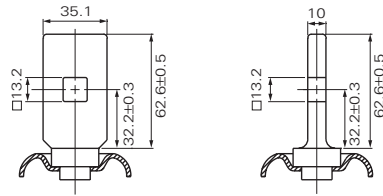

K1 Flange Fitting

H Bolt Hole Fitting

TPU Wheel Plastic hub, grey color polyurethane tire

Brake type	mm	mm		mm	mm	mm	kg	Code
Non-brake Free swivel	100	32		12.3	35.0	130.5	80	Y429H2/W427
	125	32		12.3	38.0	154.5	100	Y529H2/W527
	125	32		12.3	41.5	158.5	100	Y533H2/W527



K Flange Fitting

TPR Wheel Plastic hub, grey color thermoplastic rubber tire

Brake type	mm	mm		mm	mm	kg	Code
Non-brake Free swivel	125	32		38.0	157.5	100	Y529K1/W503
	125	32		38.0	157.5	100	Y529K1/W503U



TPU Wheel Plastic hub, grey color polyurethane tire

Brake type	mm	mm		mm	mm	kg	Code
Non-brake Free swivel	125	32		38.0	157.5	100	Y529K1/W527
	125	32		38.0	157.5	100	Y529K1/W500



Castor designed for mobile equipment used on travelator system

Pressed steel double ballrace swivel yoke, zinc-chromatized, pressed steel hub and threadguard, flanged polyurethane side disc, grey color non-marking rubber tire (80+/-5 Shore A)

Designed for the following palletsize:

Track width: approx. 2.75 mm
Groove width: approx. 5.7 mm
Groove depth: >10.0 mm

Wheel:

Disc wheel: Ø 130 mm
Disc width: 4.5 mm
Engagement travel: 8 mm

R Round Stem







SRB Wheel Pressed steel hub, grey color elastic tire

Free swivel	mm	mm		mm	mm	mm	mm	mm	mm	kg	Code
Left-hand	125	32		22.0	45.0	19.0	M8x1.25	42.5	166.3	100	Y525R8/W525L
Right-hand	125	32		22.0	45.0	19.0	M8x1.25	42.5	166.3	100	Y525R8/W525R
Fixed											
Left-hand	125	32		22.0	45.0	19.0	M8x1.25	42.5	166.3	100	Y525R8F/W525L
Right-hand	125	32		22.0	45.0	19.0	M8x1.25	42.5	166.3	100	Y525R8F/W525R



H Bolt Hole Fitting

SRB Wheel Pressed steel hub, grey color elastic tire

Free swivel	mm	mm		mm	mm	mm	kg	Code
Left-hand	125	32		10.3	42.5	163.8	100	Y525H1/W525L
	125	32		12.3	42.5	163.8	100	Y525H2/W525L
	125	32		12.8	42.5	163.8	100	Y525H3/W525L
Right-hand	125	32		10.3	42.5	163.8	100	Y525H1/W525R
	125	32		12.3	42.5	163.8	100	Y525H2/W525R
	125	32		12.8	42.5	163.8	100	Y525H3/W525R



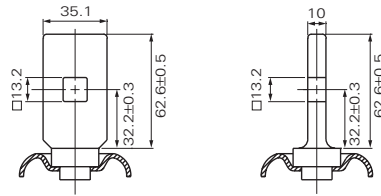

K1 Flange Fitting

K Flange Fitting

SRB Wheel Pressed steel hub, grey color elastic tire

Free swivel	mm	mm		mm	mm	kg	Code
Left-hand	125	32		42.5	166.8	100	Y525K1/W525L
Right-hand	125	32		42.5	166.8	100	Y525K1/W525R
Fixed							
Left-hand	125	32		42.5	166.8	100	Y525K1F/W525L
Right-hand	125	32		42.5	166.8	100	Y525K1F/W525R

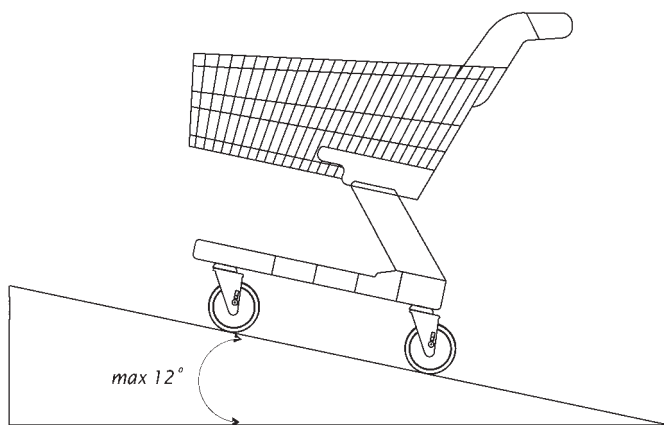

Once trolley landed on the travelator, PU side disc will drop into the pit of the belt, simultaneously locks up the wheel and prevent any movement forward or backward, allowing the user and trolley a safe ride on the travelator. Safety standard requires maximum slope of travelator does not exceed 12°.



On regular flat floor

=100kgs per castor
kg on level floor



On moving travelator

=33kgs per castor
kg on travelator