

Nitto Kohki SANDERS

Acorn Industrial Products Co

520 Hertzog Boulevard | King of Prussia, PA 19406

Phone 800-523-5474 | Fax 800-782-6780

E-Mail acorn@acornindprod.com | Web acornindprod.com

Palm Sander Features

- Compact and lightweight 1.6 lb. design
- Ergonomically designed for operator convenience and comfort
- Powerful high speed 10,000 rpm motor
- Ultra small orbital action for high quality swirl-free finishes
- Available with 5" or 6" pads
- Variable speed control



Model	Palm Sander APS-125
Air Pressure	85 psi
Air Consumption	15.9 CFM
Motor Free Speed	10,000 RPM
Orbit Diameter	3/16"
Paper Size	4-1/2" x 5-1/2"
Weight	1.6 lbs.
Pad	PSA
Spindle Thread	5/16-24
Horsepower	.37 hp
Accessories Included	spanner threaded adapter PT1/4" x NPT1/4"

Model	Palm Sander APS-150
Air Pressure	85 psi
Air Consumption	15.9 CFM
Motor Free Speed	10,000 RPM
Orbit Diameter	3/16"
Paper Size	6" dia.
Weight	1.59 lbs.
Pad	PSA
Spindle Thread	5/16-24
Horsepower	.37 hp
Accessories Included	spanner threaded adapter PT1/4" x NPT1/4"

Orbital Sander Features

- Powerful 3/4 horsepower dual action for tough applications
- Available with 5" or 6" diameter pads
- Standard with dust extraction system
- Rugged construction for years of reliable performance



Model	Orbital Sander OSV-50A
Air Pressure	85 psi
Air Consumption	24.1 CFM
Motor Free Speed	8,500 RPM
Orbit Diameter	3/8" dia.
Disc Size	5" dia.
Weight	4.2 lbs.
Pad	PSA
Horsepower	.75 hp
Accessories Included	17mm spanner wrench, dust extraction system w/dust bag, threaded adapter PT1/4" x NPT1/4"

Model	Orbital Sander OSV-60A
Air Pressure	85 psi
Air Consumption	24.1 CFM
Motor Free Speed	8,500 RPM
Orbit Diameter	3/8" dia.
Disc Size	6" dia.
Weight	4.4 lbs.
Pad	PSA
Horsepower	.75 hp
Accessories Included	17mm spanner wrench, dust extraction system w/dust bag, threaded adapter PT1/4" x NPT1/4"

Nitto Kohki SANDERS

Acorn Industrial Products Co

520 Hertzog Boulevard | King of Prussia, PA 19406

Phone 800-523-5474 | Fax 800-782-6780

E-Mail acorn@acornindprod.com | Web acornindprod.com

Free Sander Features

- Ideal for sanding and surface finishing wood, metal, plastic and other materials
- Lightweight design with minimal vibration
- High output and low air consumption motors produce high speed orbits for swirl-free finishes
- Oil free design
- Suitable for industrial and production applications



Model	Free Sander FS-100C
Air Pressure	85 psi
Air Consumption	7.1 CFM
Motor Free Speed	20,000 RPM
Orbit Diameter	1/16" dia.
Pad Size	4" x 4-3/8"
Paper Size	4-1/2" x 5-1/2"
Weight	1.1 lbs.
Accessories Included	hose E ass'y, sanding paper threaded adapter PT1/4" x NPT1/4"



Model	Free Sander FS-50A
Air Pressure	85 psi
Air Consumption	4.9 CFM
Motor Free Speed	15,000 RPM
Orbit Diameter	3/64" dia.
Pad Size	3" x 3-3/16"
Paper Size	2-3/4" x 4-1/2"
Weight	1.1 lbs.
Accessories Included	hose E ass'y, sanding paper threaded adapter PT1/4" x NPT1/4"

Line Sander Features

- Ideal for most inline and profile sanding applications
- Compact and lightweight 1.6 lb. design
- Low vibration and minimal noise output
- Suitable for sanding steel, aluminum, wood, plastic, and other materials
- Available with dust collection assembly



Model	Line Sander LS-10
Air Pressure	85 psi
Air Consumption	3.9 CFM
Strokes per minute	4,000 SPM
Stroke	532"
Pad Size	2-5/32" x 4-1/16"
Paper Size	4-1/2" x 5-1/2"
Abrasive Paper Size	2-1/4" x 5-1/2"
Weight	1.6 lbs.
Accessories Included	sanding paper, block rubber pad, hose nipple threaded adapter PT1/4" x NPT1/4"

FREE SANDER FS-100C ASSEMBLY AND PARTS LIST

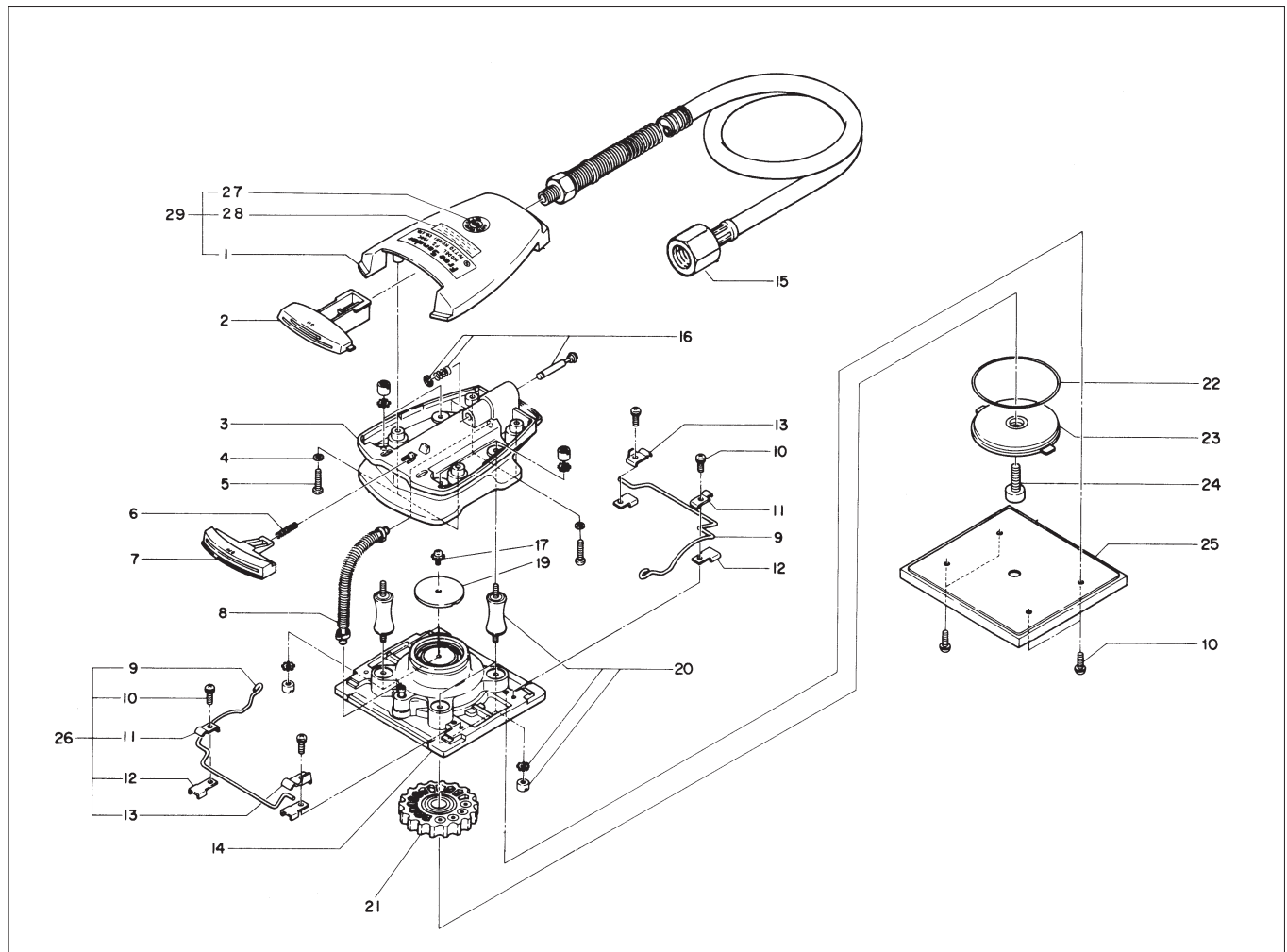

The Part Numbers with () are included in the Ass'y parts written above them.

No.	Part No.	Part Name	Q'ty	Price
29	TB02335	Housing Cover Ass'y	1 set	
1	(TP15371)	Housing Cover	1	
27	(TP04218)	Nitto Label	1	
28	(TQ02207)	Label CE-Mark	1	
2	TP15374	Trigger	1	
3	TA99365	Housing Sub Ass'y	1 set	
4	TP04234	Washer M4	4	
5	TP14488	Screw M4 X 20	4	
6	TP15376	Spring 0.45 X 3.1 X 17	1	
7	TP15375	Cancel Switch	1	
8	TA91647	Tube Ass'y	1 set	
26*	TA99971	Clamp Ass'y	2	
9	TP10870	Clamp Spring	2	
10	TP11245	+ Screw 4 X 10	8	
11	TP10872	Clamp Stopper B	2	

*Item numbers 9, 10, 11, 12 & 13 make up number 26

No.	Part No.	Part Name	Q'ty	Price
12	TP17901	Clamp Stopper C	4	
13	TP10871	Clamp Stopper A	2	
14	TA9A372	Base Plate Sub Ass'y	1 set	
15	TA92035	Hose Sub Ass'y	1 set	
16	TA99364	Throttle Valve Ass'y	1 set	
17	TA91575	+ Screw 4 X 8	1 set	
19	TP16951	Filter	1	
20	TA96330	Rubber Support Ass'y	4 sets	
21	TA9A369	Turbine Ass'y	1 set	
22	TP03790	O-Ring S-56	1	
23	TA9A371	End Cap Ass'y	1 set	
24	TP01945	Hex. Bolt 5 X 12	1	
25	TA9A367	Rubber Pad Ass'y	1 set	

ACCESSORIES

	TA91474	Convex Pad	1	
--	---------	------------	---	--

FREE SANDER FS-50A ASSEMBLY AND PARTS LIST

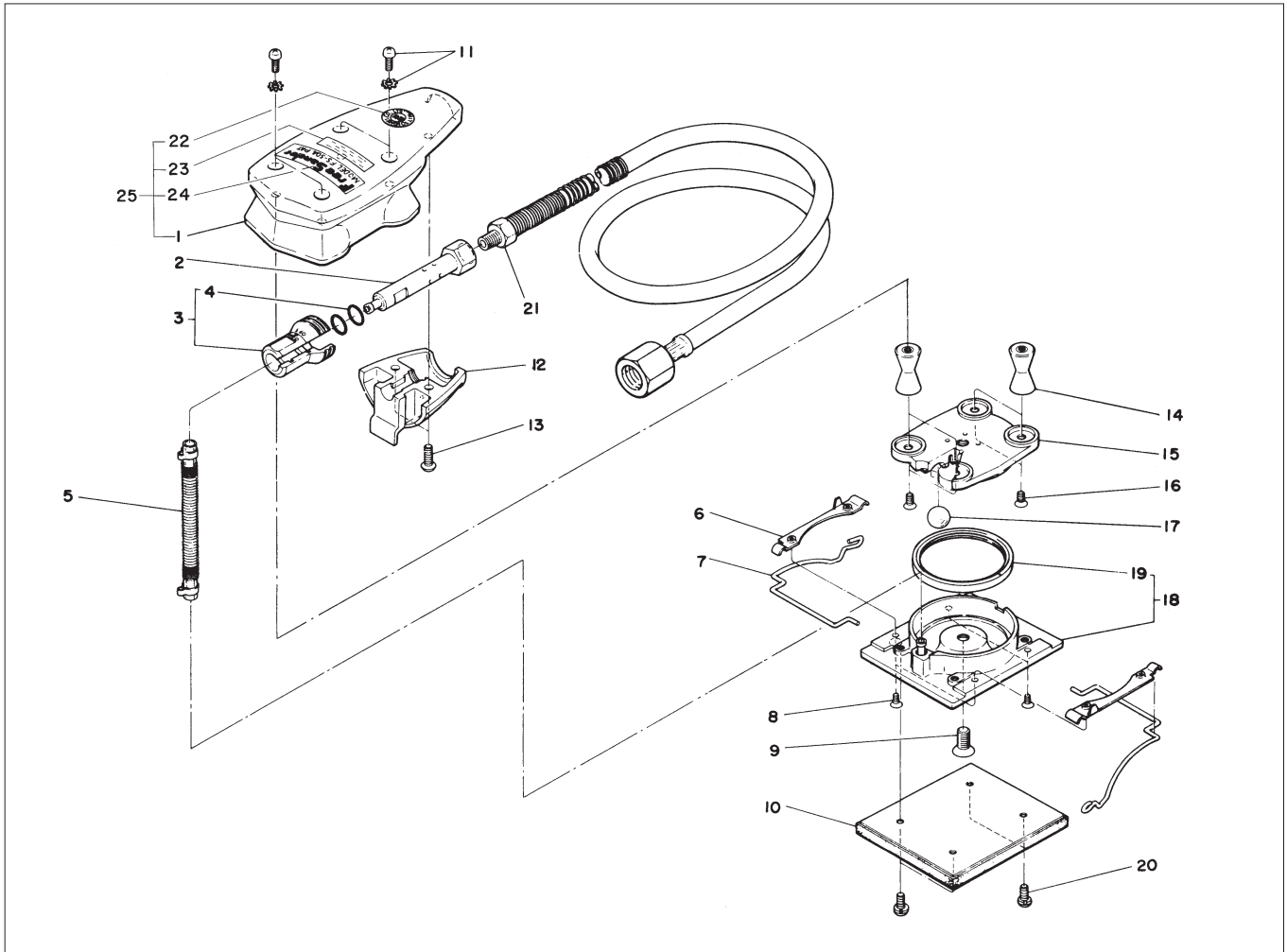

The Part Numbers with () are included in the Ass'y parts written above them.

No.	Part No.	Part Name	Q'ty	Price
25	TB05700	Housing Sub Ass'y	1 set	
1	(TP05700)	Housing	1	
22	(TP04218)	Nitto Label	1	
23	(TQ02207)	Label CE-Mark	1	
24	(TP05745)	Name Plate	1	
2	TP05698	Valve Nipple	1	
3	TP05699	Trigger	1	
4	(TP12004)	O-Ring P-10	2	
5	TA91647	Tube Ass'y	1 set	
6	TP05708	Clamp Stopper	2	
7	TP05757	Clamp Spring	2	
8	TP05709	Hex. Screw 3 X 6	4	
9	TP04226	+ Screw 6 X 14	1	

No.	Part No.	Part Name	Q'ty	Price
10	TA99828	Rubber Pad Ass'y	1 set	
11	TA91575	+ Screw 4 X 8	4 sets	
12	TP05701	Housing Cap	1	
13	TP04217	Screw 4 X 10	2	
14	TA91465	Rubber Support Ass'y	4 sets	
15	TP05705	End Plate	1	
16	TP05712	+ Screw 4 X 6	4	
17	TP05706	Ball 15/32	1	
18	TA92337	Cylinder Sub Ass'y	1 set	
19	(TP05703)	Cylinder	1	
20	TP06290	+ Screw 4 X 8	4	
21	TA92035	Hose Sub Ass'y	1 set	

LINE SANDER LS-10 ASSEMBLY AND PARTS LIST

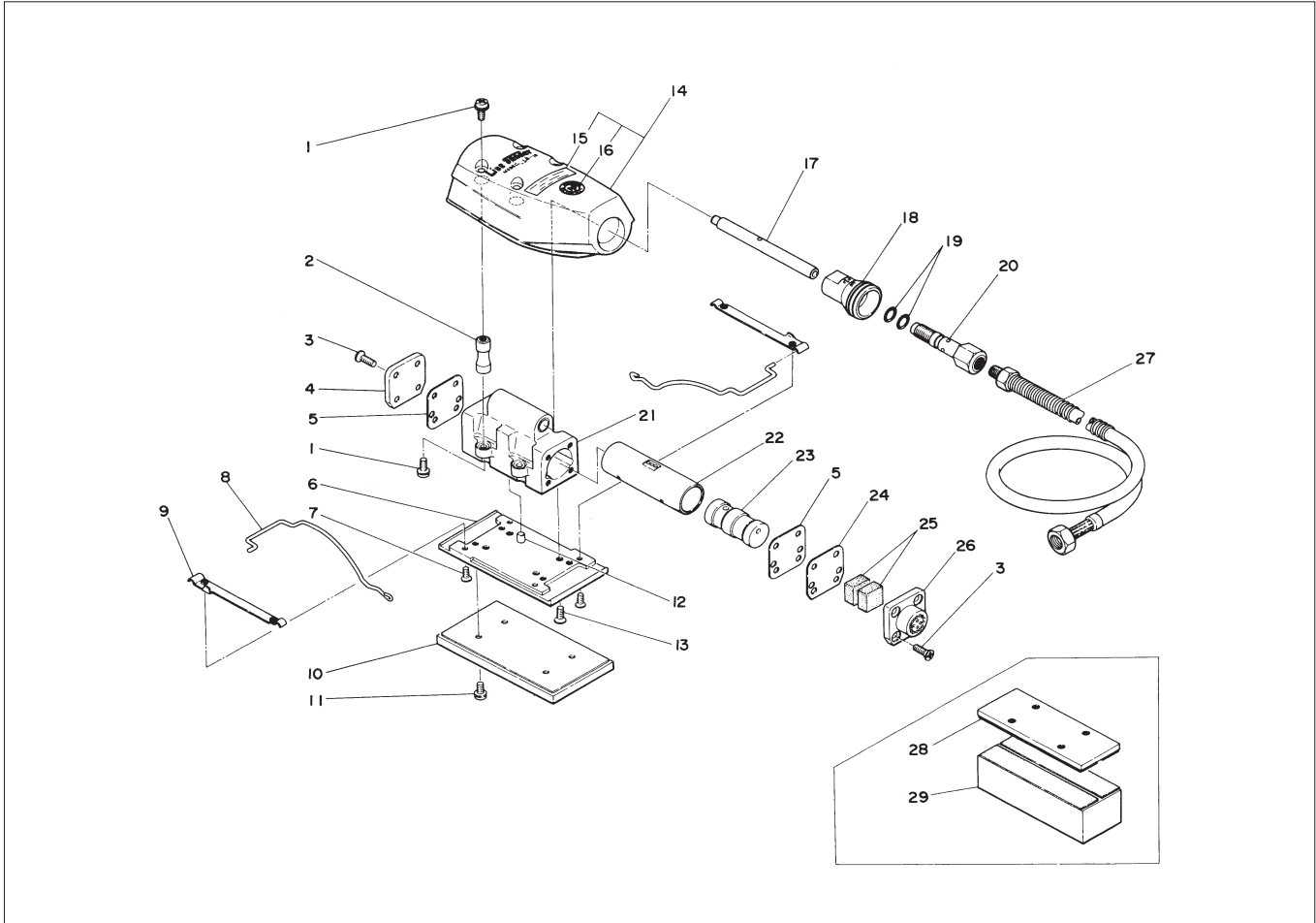

The Part Numbers with () are included in the Ass'y parts written above them.

No.	Part No.	Part Name	Q'ty	Price
1	TP11245	+ Screw 4 X 10	8	
2	TA96664	Rubber Support Ass'y	4 sets	
3	TP04217	Screw 4 X 10	8	
4	TP11249	Cap A	1	
5	TP11251	Packing	2	
6	TP11259	Base Plate	1	
7	TP05709	Hex. Screw 3 X 6	4	
8	TP11260	Clamp Spring	2	
9	TP11261	Clamp Stopper	2	
10	TA96665	Rubber Pad Ass'y	1 set	
11	TP06290	+ Screw 4 X 8	12	
12	TP12208	Parallel Pin 4 X 6.5	1	
13	TP00123	+ Screw 4 X 8	4	
14	TP11243	Housing	1 set	
15	(TQ02207)	Label CE-Mark	1	

No.	Part No.	Part Name	Q'ty	Price
16	(TP04218)	Label NITTO	1	
17	TP11244	Guide Shaft	1	
18	TP05699	Trigger	1	
19	TP12004	O-Ring P-10	2	
20	TP11258	Valve Nipple	1	
21	TA96660	Cylinder Case Sub Ass'y	1 set	
22	TP11247	Cylinder	1	
23	TP11248	Piston	1	
24	TP11254	Plate	1	
25	TP11253	Fiiter	2	
26	TP11250	Cap B	1 set	
27	TA92035	Hose Sub Ass'y	1	
28	TA96738	Base Plate A Ass'y	1 set	
29	TA96739	Block Pad Sub Ass'y	1 set	

PALM ORBITAL SANDER APS-125/150 SERIES ASSEMBLY AND PARTS LIST

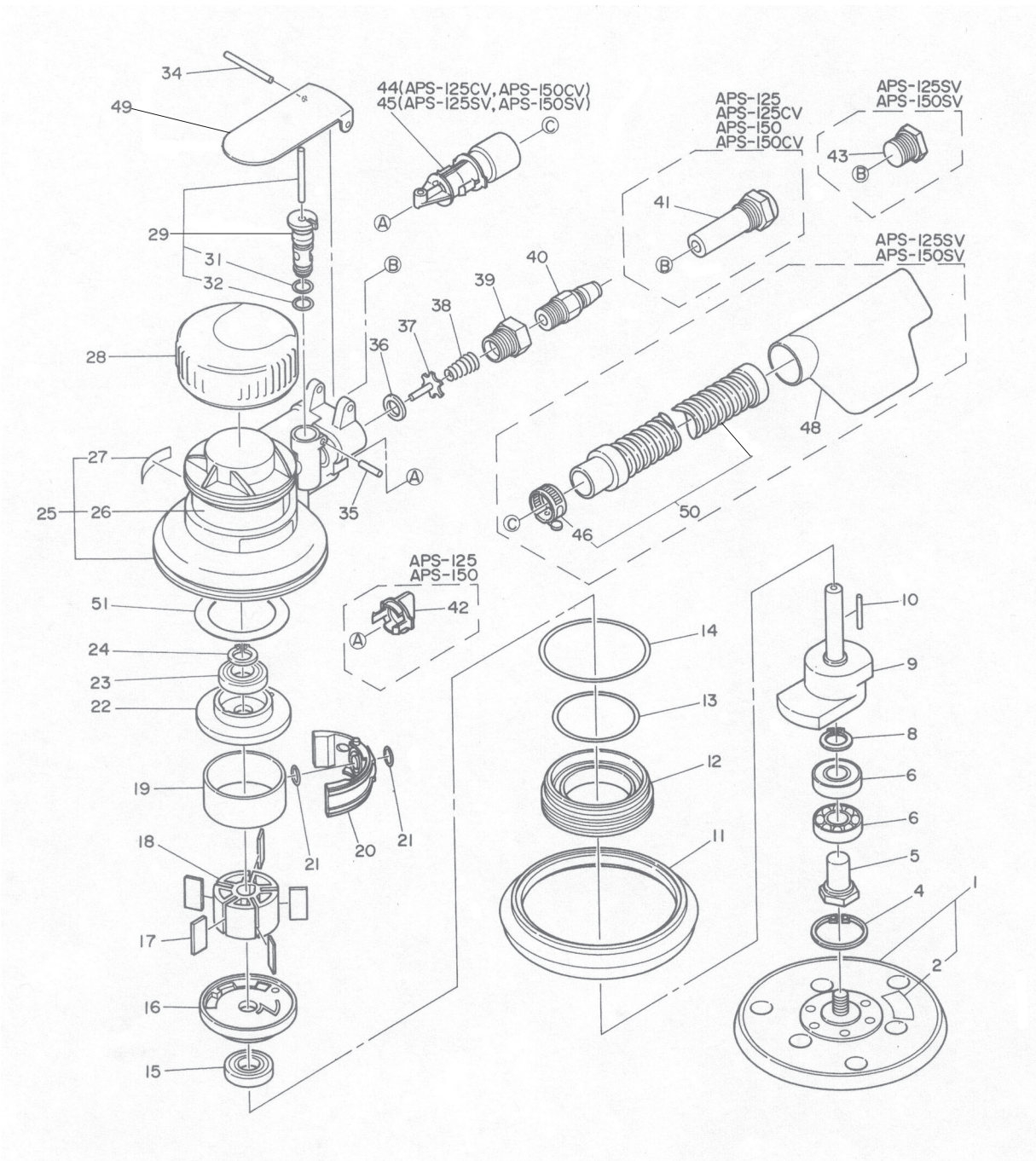

The Part Numbers with () are included in the Ass'y parts written above them.

APS-125

No.	Part No.	Part Name	Q'ty	Price
1	TB03801	Pad 5" PSA 5-Hole	1 set	
2	(TQ05090)	APS Caution Label	1	
4	TQ04650	Retaining Ring IRTW-28	1	
5	TQ04648	Spindle	1	
6	TP05650	Ball Bearing 6001DUCM	2	
8	TP03546	Retaining Ring C-12	1	
9	TQ04647	Counter Shaft 5"	1	
10	CP23473	Needle Holder	1	
11	TQ04669	Cover	1	
12	TQ05817	Lock Ring	1	
13	CQ05893	O-Ring S-44	1	
14	TP03790	O-Ring S-56	1	
15	TQ04657	Ball Bearing 6000 LLU	1	
16	TQ04652	End Plate B	1	
17	TB04867	Blades (5 pcs/set)	1 set	
18	TQ06477	Rotor	1	
19	TQ04684	Cylinder	1	
20	TQ04655	Backbone	1	
21	TP12004	O-Ring P-10	2	
22	TQ04651	End Plate A	1	
23	TP01913	Ball Bearing 6000 Z	1	
24	TQ04656	Bent Retaining Ring BG-10	1	
51	TQ04764	Spacer 52 X 38 X 0.5	1	
25	TB04429	Housing Ass'y	1 set	
26	(TQ04710)	APS Nitto Label	1	
27	(TQ04646)	APS-125 Model Number Label	1	
28	TQ04771	Rubber Grip	1	
29	TB03695	Adjust Valve Ass'y	1 set	
31	(CP20531)	O-Ring P-9	1	
32	(CP20521)	O-Ring P-8	1	
49	TB03696	Throttle Lever Ass'y	1 set	
34	TQ04661	Spring Pin 3 X 36 AW	1	
35	TP15729	Spring Pin 3 X 14	1	
36	TQ04671	Seal Sheet 9 X 13.9 X 2	1	
37	TQ04664	Valve	1	
38	TQ04665	Conical Spring 0.8 X 6.4 X 11.6	1	
39	TQ04666	Bushing M16 X PT1/4	1	
41	TB03593	Muffler Ass'y	1 set	
53	TQ05088	O-Ring SS-100	1	
42	TQ04667	Cap	1	
	TQ06276	Oil Daily Label		

APS-125SV

No.	Part No.	Part Name	Q'ty	Price
25	TB04429	Housing Ass'y	1 set	
26	(TQ04710)	APS Nitto Label	1	
27	(TQ04693)	Model Number APS-125SV Label	1	
43	TQ04685	Hex. Head Bolt M16 X 11 P1.5	1	
45	TB03594	Ejector Ass'y	1 set	
50	TA99239	Hose Ass'y	1 set	
46	(TP05662)	Hose Band	1	
48	TP14836	Dust Collection Bag	1	
52	LQ02848	P-Tite Screw	1	

APS-125CV

No.	Part No.	Part Name	Q'ty	Price
25	TB04431	Housing Ass'y	1 set	
26	(TQ04710)	Label Nitto APS	1	
27	(TQ04689)	Label Model Number APS-125CV	1	
41	TB03593	Muffler Ass'y	1 set	
44	TQ04682	Ejector	1	
52	LQ02848	P-Tite Screw	1	
53	TQ05088	O-Ring SS-100	1	

ACCESSORIES

	TP00474	Spanner 17	1	
	TP02236	Bushing PT 1/4 X NPT 1/4	1	
	TQ04674	Instruction Manual	1	
	TB03669	Pad 5" Velcro 5 Hole	1 set	

The Part Numbers with () are included in the Ass'y parts written above them.

APS-150

No.	Part No.	Part Name	Q'ty	Price
1	TB03885	Pad 6" PSA 6 Hole	1 set	
2	(TQ05090)	APS Caution Label	1	
4	TQ04650	Retaining Ring IRTW-28	1	
5	TQ04648	Spindle	1	
6	TP05650	Ball Bearing 6001DUCM	2	
8	TP03546	External Retaining Ring C-12	1	
9	TQ04679	Counter Shaft	1	
10	CP23473	Needle Holder	1	
11	TQ04669	Cover	1	
12	TQ05817	Lock Ring	1	
13	CQ05893	O-Ring S-44	1	
14	TP03790	O-Ring S-56	1	
15	TQ04657	Ball Bearing 6000 LLU	1	
16	TQ04652	End Plate B	1	
17	TB04867	Blades (5 pcs/set)	1 set	
18	TQ06477	Rotor	1	
19	TQ04684	Cylinder	1	
20	TQ04655	Backbone	1	
21	TP12004	O-Ring P-10	2	
22	TQ04651	End Plate A	1	
23	TP01913	Ball Bearing 6000 Z	1	
24	TQ04656	Bent Retaining Ring BG-10	1	
51	TQ04764	Spacer 52 X 38 X 0.5	1	
25	TB04435	Housing Ass'y	1 set	
26	(TQ04710)	APS Nitto Label	1	
27	(TQ04678)	Model Number APS-150 Label	1	
28	TQ04771	Rubber Grip	1	
29	TB03695	Adjust Valve Ass'y	1 set	
31	(CP20531)	O-Ring P-9	1	
32	(TP20521)	O-Ring P-8	1	
49	TB03696	Throttle Lever Ass'y	1 set	
34	(TQ04661)	Spring Pin 3 X 36 AW	1	
35	TP15729	Spring Pin 3 X 14	1	
36	TQ04671	Seal Sheet 9 X 13.9 X 2	1	
37	TQ04664	Valve	1	
38	TQ04665	Conical Spring 0.8 X 6.4 X 11.6	1	
39	TQ04666	Bushing M16 X PT 1/4	1	
41	TB03593	Muffler Ass'y	1 set	
53	TQ05088	O-Ring SS-100	1	
42	TQ04667	Cap	1	

APS-150SV

No.	Part No.	Part Name	Q'ty	Price
25	TB04439	Housing Ass'y	1 set	
26	(TQ04710)	APS Nitto Label	1	
27	(TQ04695)	Model Number APS-150SV Label	1	
43	TQ04685	Hex. Head Bolt M16 X 11 P.1.5	1	
45	TB03594	Ejector Ass'y	1 set	
50	TA99239	Hose Ass'y	1 set	
46	(TP05662)	Hose Band	1	
48	TP14836	Dust Collection Bag	1	
52	LQ02848	P-Tite Screw	1	

APS-150CV

No.	Part No.	Part Name	Q'ty	Price
25	TB04431	Housing Ass'y	1 set	
26	(TQ04710)	APS Nitto Label	1	
27	(TQ04691)	Model Number APS-150CV Label	1	
41	TB03593	Muffler Ass'y	1 set	
44	TQ04682	Ejector	1	
52	LQ02848	P-Tite Screw	1	
53	TQ05088	O-Ring SS-100	1	

ACCESSORIES

No.	Part No.	Part Name	Q'ty	Price
	TP00474	Spanner 17	1	
	TP02236	Bushing PT1/4 X NPT1/4	1	
	TQ04674	Instruction Manual	1	
	TB03650	Pad 6" Velcro 6-Hole	1 set	

ORBITAL SANDER OSV-60A ASSEMBLY AND PARTS LIST

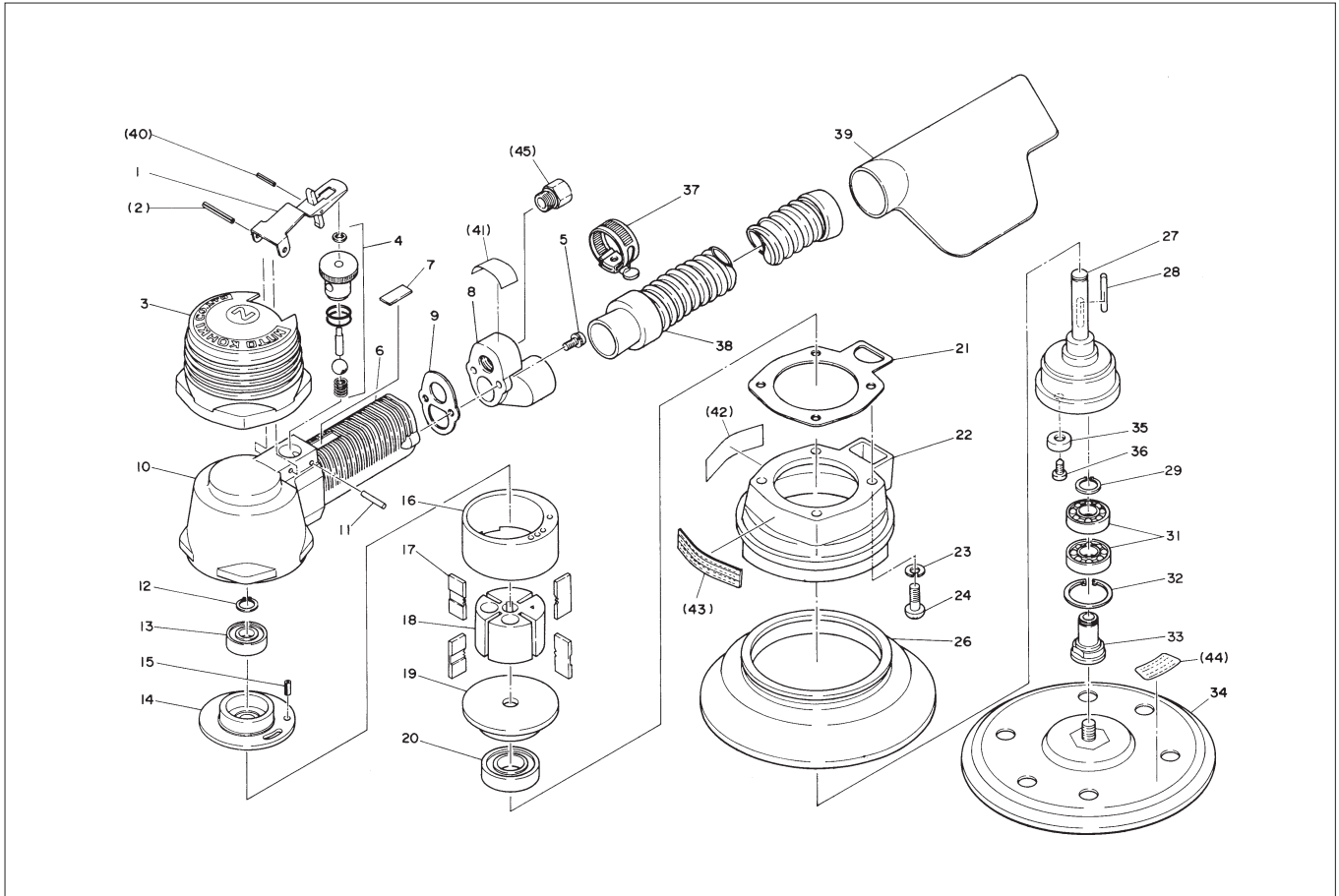

The Part Numbers with () are included in the Ass'y parts written above them.

No.	Part No.	Part Name	Q'ty	Price
1	TB02151	Throttle Lever Ass'y	1 set	
2	(TP01802)	Spring Pin 3 X 28	1	
40	(TP05498)	Spring Pin 2 X 16	1	
3	TP14808	Housing Cover	1	
4	TA99063	Valve Ass'y	1 set	
5	LP30942	Screw 4 X 14	2	
6	TP14810	Grip Tube	1	
7	TQ02790	Lever Wear Plate	1	
8	TB02276	Rear Cap Ass'y	1 set	
41	(TQ02207)	Label CE-Mark	1	
9	TP14804	Gasket A	1	
10	TP14809	Housing	1	
11	TP20537	Spring Pin 3 X 21.8	1	
12	TP04595	Retaining Ring C-10	1	
13	TP01913	Ball Bearing 6000 Z	1	
14	TP14817	End Plate A	1	
15	TP08932	Spring Pin 4 X 8	1	
16	TP14820	Cylinder	1	
17	TA9A288	Blades (4 pcs/set)	1 set	
18	TP05980	Rotor	1	
19	TP14818	End Plate B	1	
20	TQ01504	Ball Bearing 6003LLB	1	
21	TP14811	Gasket B	1	
22	TB02218	Base Cover Ass'y	1 set	
42	(TQ02915)	Warning Label - OSV-60A	1	

No.	Part No.	Part Name	Q'ty	Price
43	(TQ02923)	Plate Model Number OSV-60A	1	
23	TP00513	Spring Washer M5	4	
24	LP30138	+ Screw 5 X 14	4	
26	TP14875	Cover 6"	1	
27	TP14869	Counter Shaft	1	
28	TP14822	Sunk Key 2.5 X 3.8 X 20	1	
29	TP03546	Retaining Ring C-12	1	
31	TP05650	Ball Bearing 6001DUCM	2	
32	TP01036	Retaining Ring C-28	1	
33	TP05984	Spindle	1	
34	TB03898	Pad 6" B-H Ass'y	1 set	
44	(TP16713)	Caution Label	1	
35	TP14876	Weight	1	
36	TP05986	- Screw 5 X 8	1	
37	TP05662	Hose Band	1	
38	TA99239	Hose Ass'y	1	
39	TP14836	Dust Collection Bag	1	
45	TQ00857	Bushing M16 X PT1/4	1	

ACCESSORIES

	TB03890	Pad 5" V-H Ass'y - Velcro	1	
	U40022	Pad 5" w/holes - PSA	1	
	U40021	Pad 5" w/o holes - PSA	1	
	TP14868	5" Cover	1	